



>>>>IMPORTANT NOTICE<<<<

Friday, November 11, 2011

To Whom It May Concern:

We are reviewing how our VGA 640 X 480 Low Power AMOLED Microdisplay series (Part number EMA-100600 and EMA-100601) should be classified under U.S. export laws and are planning to submit a commodity jurisdiction request. Until our review is complete, the VGA microdisplay should be treated as an item whose export is regulated by the U.S. Department of State in accordance with the guidance of "International Traffic in Arms Regulations (ITAR)" per Title 22, Code of Federal Regulations, Parts 120-130. We will contact you when our review is complete.

Thanks for your cooperation.

eMagin Corporation

3006 Northup Way - Suite 103 - Bellevue, WA 98004
P: (425) 284-5200 F: (425) 284-5201
www.eMagin.com

VGA

640 X 480 LOW POWER COLOR AMOLED MICRODISPLAY

DATASHEET

Revision 1.1

For Part Numbers:

Color VGA Microdisplay: EMA-100601

Monochrome White VGA Microdisplay: EMA-100600

eMagin Corporation reserves the right to change products and specifications without prior notice. This information does not convey any license by any implication or otherwise under any patents or other rights. Application circuits shown, if any, are typical examples illustrating the operation of the devices. eMagin Corporation cannot assume responsibility for any problem arising out of the use of these circuits

Revision Level	Date	Scope
0.1	05-20-09	First Draft
0.2	12-11-09	Second Draft
0.3	12-15-09	Third Draft
0.4	07-1-10	Fourth Draft
1.0	09-2-10	Initial Release
1.1	05-3-11	Initial Release – First Revision

TABLE OF CONTENTS

1.	INTRODUCTION.....	5
2.	GENERAL DESCRIPTION	6
3.	FUNCTIONAL OVERVIEW	7
4.	INPUT / OUTPUT DESCRIPTION.....	9
4.1	MONOCHROME VGA INPUT / OUTPUT DESCRIPTION	9
4.2	COLOR VGA INPUT / OUTPUT DESCRIPTION	10
5.	PIXEL ARRAY LAYOUT	11
6.	ELECTRICAL CHARACTERISTICS.....	12
6.1	TIMING CHARACTERISTICS.....	15
6.1.1	Interface Timing Diagrams.....	15
6.1.2	Gamma Sensor Timing Diagram	16
7.	OPTICAL CHARACTERISTICS.....	18
8.	MECHANICAL CHARACTERISTICS.....	20
8.1	COLOR VGA CONFIGURATION	21
8.2	MONOCHROME VGA CONFIGURATION	21
9.	DETAILED FUNCTIONAL DESCRIPTION	22
9.1	VIDEO INPUT INTERFACE.....	22
9.1.1	Gamma Correction	22
9.1.2	Row Data Expansion	24
9.2	D/A CONVERSION	24
9.3	FORMAT AND TIMING CONTROL	25
9.3.1	Interlaced Mode.....	26
9.3.2	Stereovision.....	26
9.4	SENSOR FUNCTIONS	27
9.4.1	Temperature Readout	27
9.4.2	Luminance Regulation Sensor	28
9.4.3	Pixel Bias Sensor	28
9.4.4	Luminance Control (Analog Dimming)	28
9.4.5	Luminance Control (PWM Dimming).....	29
9.4.6	Gamma Correction Sensor	30
9.5	DC-DC CONVERTER	32
9.6	I ² C SERIAL INTERFACE.....	34
9.7	POWER-ON SEQUENCE	35
9.8	POWER-SAVINGS MODE.....	37
9.8.1	Display-Off Function.....	38
10.	REGISTER MAP SUMMARY	39
11.	DETAILED REGISTER DESCRIPTIONS.....	41
11.1	STAT (00H)	41
11.2	VINMODE (01H)	41
11.3	DISPMODE (02H).....	42
11.4	TOPPOS (03H)	43

11.5	BOTPOS (04H).....	44
11.6	ROWRESET (05H).....	44
11.7	RAMPCTL (06H)	45
11.8	RAMPCM (07H).....	45
11.9	VDACMX (08H).....	46
11.10	BIASN (09H)	47
11.11	GAMMASET (0AH).....	48
11.12	VCOMMODE (0BH).....	49
11.13	VCOMCTL (0CH).....	49
11.14	VGMAX (0DH)	50
11.15	VCOM (0EH).....	51
11.16	IDRF (0FH).....	52
11.17	DIMCTL (10H).....	53
11.18	TREFDIV (11H)	53
11.19	TEMPOFF (12H)	53
11.20	TUPDATE (13H).....	54
11.21	TEMPOUT (14H)	54
11.22	ANGPWRDN (15H).....	56
11.23	SYSPWRDN (16H).....	57
11.24	TPMODE (17H).....	58
11.25	TPLINWTH (18H).....	59
11.26	TPCOLSP (19H)	60
11.27	TPROWSP (1AH).....	60
11.28	TPCOLOR (1BH)	60
11.29	DIGTEST (1CH).....	61
11.30	PUCTRL (2EH).....	61
11.31	HIDDEN (2FH).....	61
12.	APPENDIX A: APPLICATION SYSTEM DIAGRAM.....	62
13.	APPENDIX B: MICRODISPLAY CARRIER BOARD.....	63
14.	APPENDIX C: TYPICAL REGISTER SETTING.....	64

1. INTRODUCTION

The VGA XL device from eMagin Corporation is an active-matrix organic light emitting diode (AMOLED) microdisplay intended for near-to-eye applications that demand high image quality, compact size, and very low power. Combining a total of 1,060,800 active OLED dots, the VGA display is built on a single crystal silicon backplane and features eMagin's proprietary thin-film OLED XL technology offering extended life and luminance performance.

The active array is comprised of 680 x 520 square pixels with a 15-micron pitch and a 75% fill factor. An extra 20 columns and 20 rows (beyond the 640 x 480 main array) are provided to enable the active VGA display to be shifted by steps of 1 pixel in the X and Y directions for temporal dithering or optical alignment purposes. Additional dummy and test pixels surround the active array. Each full pixel is laid out as three 5 x 15 micron identical sub-pixels, which together form the 15-micron square RGB color group. Three primary color filter stripes are applied in alignment with the sub-pixels on a white-emissive OLED layer to form the color display. Monochrome capability is accomplished by building the display without color filter, and configuring it for monochrome use. In this case, each pixel has a built-in triple redundancy (3 sub-pixels per pixel sharing the same information)

The VGA design features eMagin's proprietary "Deep Black" architecture that ensures off- pixels are truly black, automatically optimizes contrast under all conditions, and delivers improved pixel uniformity. Video data is received via an extended 30-bit digital RGB interface with external synchronization and clocks, and the display includes on-chip digital to analog conversion, automatic luminance regulation over the full temperature range, automatic gamma correction, and programmable brightness. A dedicated monochrome mode allows the use of a single 10-bit input path in order to minimize power consumption.

The VGA display system provides broad versatility and flexibility for the user through application of a separate FPGA driver IC or integration of drive logic into the user's electronics using eMagin provided source code. The driver IC provides control over gamma, color balance, contrast, brightness, electronic optical alignment, and video formatting.

Detailed device specifications and application information for the VGA XL microdisplay produced by eMagin Corporation are provided in this document.

2. GENERAL DESCRIPTION

Parameter	Specification ¹
Display Type	Emissive, Color Active Matrix Organic Light Emitting Diode on Silicon
Format	640 (x3) x 480 pixels
Total Pixel Array	680 (x3) x 520 pixels
Color Pixel Aspect Ratio	15 micron square color group
Color Pixel Arrangement	R, G, B Vertical Stripe
Display Area	10.02 x 7.80 mm (12.84 mm diagonal, 0.50")
Useable Display Area	9.6 x 7.2 mm (12.0 mm diagonal, 0.47")
Mechanical Envelope	16.5 x 18 x 5.01 mm (rigid carrier board)
Weight	~ 2 grams
Gray Levels	256 per primary color
Uniformity	> 90% end to end
Contrast Ratio	> 10,000:1 typical
Dimming Ratio	>400:1 with CR> 1,000:1 typical
White Luminance (Color display)	≥ 150 cd/m ² (front luminance), VGA 60Hz VESA mode
Video Interface	RGB 30-bit Digital 2.5V CMOS
Video Source Clock	50 MHz maximum (VESA mode), up to 120 Hz frame rate
Control & Serial Interface	Digital 2.5V CMOS
Power Interface	
IO/Front-end Supply (VDD)	2.5 Volts DC @ 5 mA maximum
Array/Analog Supply ² (VAN)	5.0 Volts DC @ 25 mA maximum
Bias Supply (VPG)	-1.5 Volts DC @ 1 nA maximum
Operating Ambient Temperature	-46°C to +70°C
Storage Temperature	-55°C to +90°C
Humidity	85%RH non-condensing

Note 1: The above data represents performance specifications, measured at 20°C.

Note 2: Includes internally generated negative cathode supply.

3. FUNCTIONAL OVERVIEW

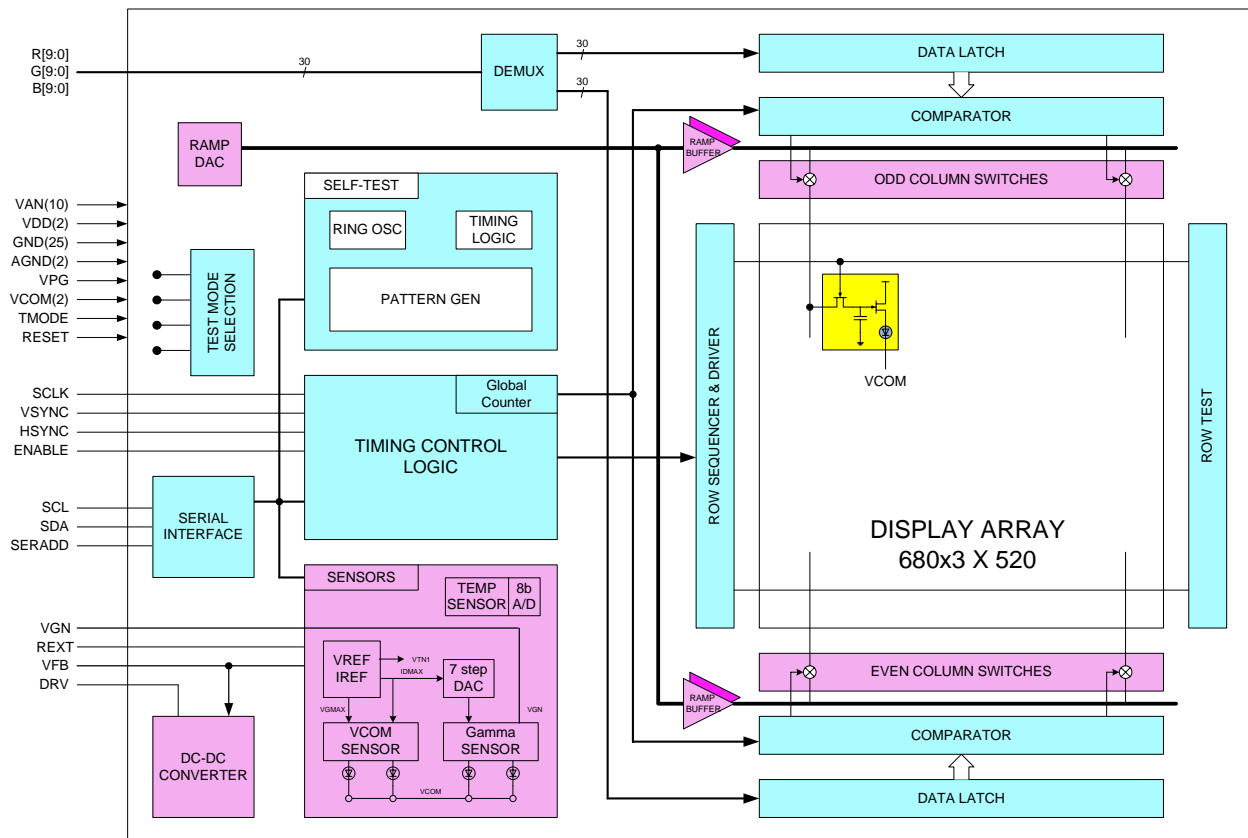

Figure 1 : VGA design block diagram

The top-level block diagram for the VGA microdisplay is shown in Figure 1. Bi-directional row and column sequencer circuits are used for addressing individual cells within the 680 x 520 x 3 pixel array, and internal digital-to-analog conversion circuits are included for converting the digital input data into the analog signals needed for programming the pixels. A storage element (capacitor) resides at each pixel cell that is used to set the gray level.

The digital video input data is applied individually to each of the three RGB sub-pixels of the color group in color mode. The RGB data inputs that make up the digital data port are configured as three 10-bit data busses. Odd columns are driven by data sequencers located at the top of the array and even columns by bottom side sequencers. To obtain a linear gray-scale response from the OLED pixels the digital input data must be formatted with Gamma correction.

In monochrome mode, a single 10-bit input port is used, and a single 10-bit datapath is used internally to minimize power consumption. A demultiplexer switch applies the single data to the three columns that make up the pixel. The other two data channels are powered down.

The pixel clock and sync signals for various video formats are supplied externally and converted into individual control signals by the internal timing logic block.

Both progressive and interlaced modes are available and configured via the register-based interface.

The sensor block provides a number of signals for setting and regulating the display operation. These include a digital readout of the on-chip temperature, a reference level for maintaining constant luminance over temperature, a gamma correction feedback signal, and internal reference levels used for programming luminance over a wide range.

An on-chip dc-to-dc converter controller allows for the generation of the OLED cathode supply, relying on a few external passive components. The converter is an adjustable inverter that converts VAN to a negative supply used to bias the cathodes connected in common for all the array pixels via the VCOM input.

The 2-wire serial interface is a slave only I²C compatible controller with a programmable address via an external pin (LSB). The interface provides access (read and write) to on chip registers. The registers will allow the display to be configured for its various video modes and associated clock parameters. Additional control settings include luminance control, image orientation and position, internal vs. external function selection, self-test mode and various sensor settings.

The RESETB pin provides an asynchronous hardware reset function. When this pin is set to zero the display will turn off and the internal registers will be reset to their default state. After this pin is released (set to VDD), bit DISPOFF in register DISPMODE must be set high in order for the display to turn-on. If unused, this pin may be left unconnected.

The display also includes extensive functionality to support test and manufacturability including scantest for the logic blocks, row/column continuity test, JTAG pad continuity test, and a built-in test pattern generator.

Table 3-1 : VGA Microdisplay Video Formats

Format (columns x rows)	Name	Input Mode	Output (Display) Mode
640 x 480 Color / Mono	VGA	Progressive Scan	Progressive Scan
640 x 480 Color / Mono	VGA	Interlaced Scan	Interlaced Scan

4. INPUT / OUTPUT DESCRIPTION

Two configurations are available:

- Monochrome VGA Microdisplay
- Color VGA Microdisplay

4.1 Monochrome VGA Input / Output Description

Miniature 30 pin connector part number: Hirose DF12D (3.0)-30DP-0.5V

Table 4-1 : Input / Output Pin Description for monochrome display

Pin #	Pin Name	I/O	Signal Level	Description
1	VDD2.5	IN	Power	Logic and I/O power supply (2.5V)
2	VDD5	IN	Power	Analog and Array power supply (5V)
3	SCL	IN	Digital	Clock port for the serial interface (400 KHz Max) (5V tolerant)
4	SDA	IN/OUT	Digital	Data port for the serial interface (5V tolerant)
5	SERADD	IN	Digital	Serial Interface LSB address bit. Must be connected. (2.5V CMOS)
6	GND	IN	Power	Power return terminal
7	RD0	IN	Digital	Parallel 10-bit digital Red inputs. (2.5V CMOS)
8	VPG	IN	Power	Negative supply for array protection (-1.5V)
9	D1	IN	Digital	Parallel 10-bit digital Red inputs. (2.5V CMOS)
10	BI	IN	Digital	Burn In Mode selection pin. Active high. Internal pull-down. (2.5V CMOS)
11	D2	IN	Digital	Parallel 10-bit digital Red inputs. (2.5V CMOS)
12	VGN	OUT	Analog	Gamma sensor feedback signal (0 to 5V/2.5V analog output)
13	D3	IN	Digital	Parallel 10-bit digital Red inputs. (2.5V CMOS)
14	GND	IN	Power	Power return terminal
15	D4	IN	Digital	Parallel 10-bit digital Red inputs. (2.5V CMOS)
16	VSYNC	IN	Digital	Vertical Sync logic input. (2.5V CMOS)
17	D5	IN	Digital	Parallel 10-bit digital Red inputs. (2.5V CMOS)
18	HSYNC	IN	Digital	Horizontal Sync logic input. (2.5V CMOS)
19	D6	IN	Digital	Parallel 10-bit digital Red inputs. (2.5V CMOS)
20	DE	IN	Digital	Data Enable logic input used with loading RGB data. (2.5V CMOS)
21	D7	IN	Digital	Parallel 10-bit digital Red inputs. (2.5V CMOS)
22	GND	IN	Power	Power return terminal
23	D8	IN	Digital	Parallel 10-bit digital Red inputs. (2.5V CMOS)
24	SCLK	IN	Digital	Source clock input. (2.5V CMOS)
25	D9	IN	Digital	Parallel 10-bit digital Red inputs. (2.5V CMOS)
26	ENABLE	IN	Digital	Enable logic input. When inactive, blocks row and column sequencers. (2.5V CMOS)
27	GND	IN	Power	Power return terminal
28	RESETB	IN	Digital	Asynchronous System Reset. Active low. Internal pull-up. (2.5V CMOS)

4.2 Color VGA Input / Output Description

Miniature 50 pin connector part number: Hirose DF12D(3.0)-50DP-0.5V

Table 4-2 : Input / Output Pin Description for monochrome display

Pin #	Pin Name	I/O	Signal Level	Description
1	VDD2.5	IN	Power	Logic and I/O power supply (2.5V)
2	VDD5	IN	Power	Analog and Array power supply (5V)
3	SCL	IN	Digital	Clock port for the serial interface (400 KHz Max) (5V tolerant)
4	VDD5	IN	Power	Analog and Array power supply (5V)
5	SDA	IN/OUT	Digital	Data port for the serial interface (5V tolerant)
6	EXT_RAMP	IN/OUT	Analog	External analog ramp input signal (0 to 5V range). Tie 20pF cap to GND when not in use.
7	SERADD	IN	Digital	Serial Interface LSB address bit. Must be connected. (2.5V CMOS)
8	GND	IN	Power	Power return terminal
9	RD0	IN	Digital	Parallel 10-bit digital Red inputs. (2.5V CMOS)
10	VPG	IN	Power	Negative supply for array protection (-1.5V)
11	RD1	IN	Digital	Parallel 10-bit digital Red inputs. (2.5V CMOS)
12	BI	IN	Digital	Burn In Mode selection pin. Active high. Internal pull-down. (2.5V CMOS)
13	RD2	IN	Digital	Parallel 10-bit digital Red inputs. (2.5V CMOS)
14	VGN	OUT	Analog	Gamma sensor feedback signal (0 to 5V/2.5V analog output)
15	RD3	IN	Digital	Parallel 10-bit digital Red inputs. (2.5V CMOS)
16	GND	IN	Power	Power return terminal
17	RD4	IN	Digital	Parallel 10-bit digital Red inputs. (2.5V CMOS)
18	VSYNC	IN	Digital	Vertical Sync logic input. (2.5V CMOS)
19	RD5	IN	Digital	Parallel 10-bit digital Red inputs. (2.5V CMOS)
20	HSYNC	IN	Digital	Horizontal Sync logic input. (2.5V CMOS)
21	RD6	IN	Digital	Parallel 10-bit digital Red inputs. (2.5V CMOS)
22	DE	IN	Digital	Data Enable logic input used with loading RGB data. (2.5V CMOS)
23	RD7	IN	Digital	Parallel 10-bit digital Red inputs. (2.5V CMOS)
24	GND	IN	Power	Power return terminal
25	RD8	IN	Digital	Parallel 10-bit digital Red inputs. (2.5V CMOS)
26	SCLK	IN	Digital	Source clock input. (2.5V CMOS)
27	RD9	IN	Digital	Parallel 10-bit digital Red inputs. (2.5V CMOS)
28	ENABLE	IN	Digital	Enable logic input. When inactive, blocks row and column sequencers. (2.5V CMOS)
29	GND	IN	Power	Power return terminal
30	RESETB	IN	Digital	Asynchronous System Reset. Active low. Internal pull-up. (2.5V CMOS)
31	BL0	IN	Digital	Parallel 10-bit digital Blue inputs. (2.5V CMOS)
32	GN9	IN	Digital	Parallel 10-bit digital Green inputs. (2.5V CMOS)
33	BL1	IN	Digital	Parallel 10-bit digital Blue inputs. (2.5V CMOS)
34	GN8	IN	Digital	Parallel 10-bit digital Green inputs. (2.5V CMOS)
35	BL2	IN	Digital	Parallel 10-bit digital Blue inputs. (2.5V CMOS)
36	GN7	IN	Digital	Parallel 10-bit digital Green inputs. (2.5V CMOS)
37	BL3	IN	Digital	Parallel 10-bit digital Blue inputs. (2.5V CMOS)
38	GN6	IN	Digital	Parallel 10-bit digital Green inputs. (2.5V CMOS)
39	BL4	IN	Digital	Parallel 10-bit digital Blue inputs. (2.5V CMOS)
40	GN5	IN	Digital	Parallel 10-bit digital Green inputs. (2.5V CMOS)
41	BL5	IN	Digital	Parallel 10-bit digital Blue inputs. (2.5V CMOS)
42	GN4	IN	Digital	Parallel 10-bit digital Green inputs. (2.5V CMOS)
43	BL6	IN	Digital	Parallel 10-bit digital Blue inputs. (2.5V CMOS)
44	GN3	IN	Digital	Parallel 10-bit digital Green inputs. (2.5V CMOS)
45	BL7	IN	Digital	Parallel 10-bit digital Blue inputs. (2.5V CMOS)
46	GN2	IN	Digital	Parallel 10-bit digital Green inputs. (2.5V CMOS)
47	BL8	IN	Digital	Parallel 10-bit digital Blue inputs. (2.5V CMOS)
48	GN1	IN	Digital	Parallel 10-bit digital Green inputs. (2.5V CMOS)
49	BL9	IN	Digital	Parallel 10-bit digital Blue inputs. (2.5V CMOS)
50	GN0	IN	Digital	Parallel 10-bit digital Green inputs. (2.5V CMOS)

5. PIXEL ARRAY LAYOUT

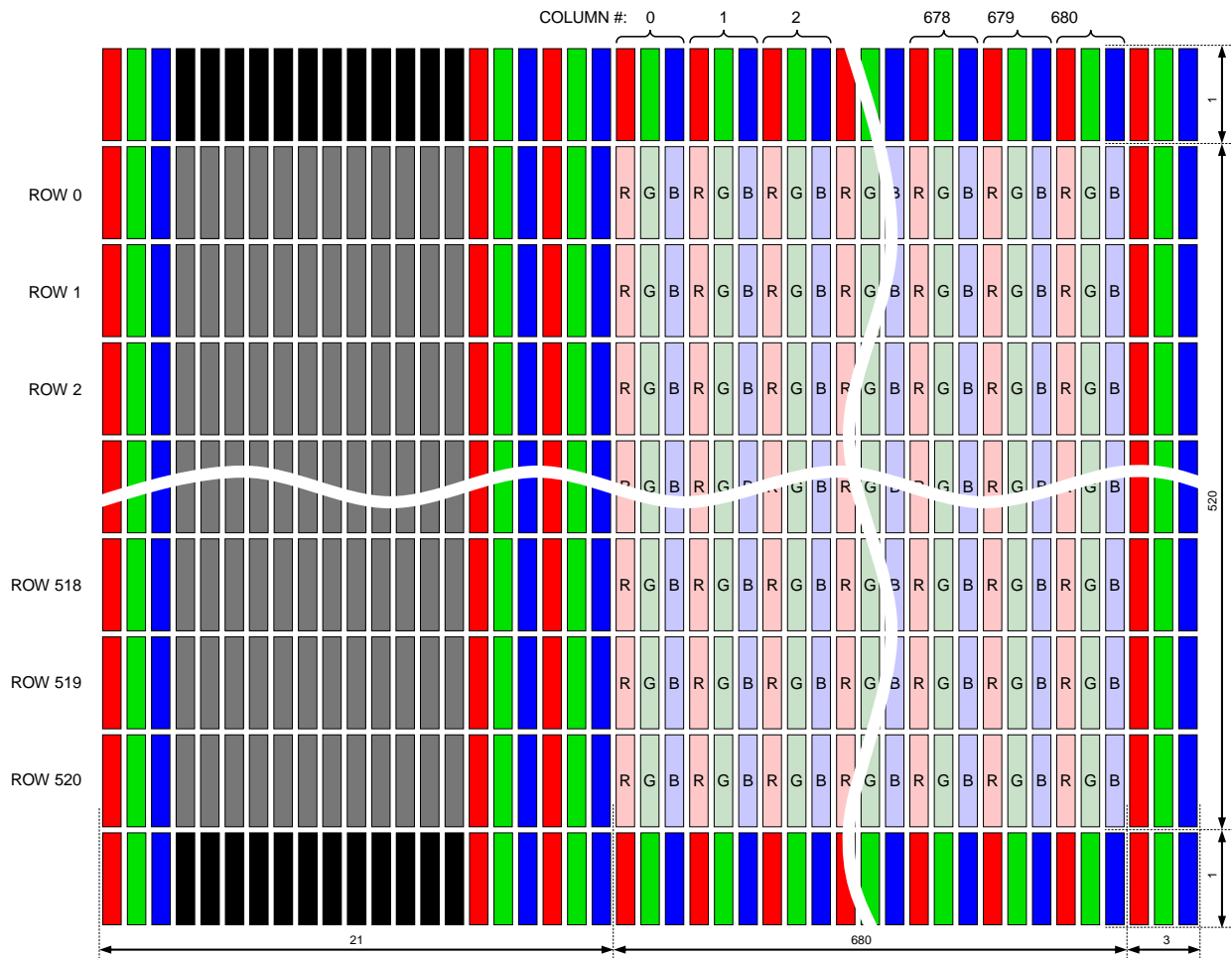

6. ELECTRICAL CHARACTERISTICS

Table 6-1 : Absolute Maximum Ratings

Symbol	Parameter	Min	Typ.	Max.	Unit
VDD	Front End Power Supply	-0.3		2.75	VDC
VAN	Array Power Supply	-0.3		5.5	VDC
VCOM	Common electrode bias	-6		0	VDC
VPG	Array Bias Supply	-3		0	VDC
VI	Input Voltage Range	-0.3		VDD+0.3	VDC
VO	Output Voltage Range	-0.3		VDD+0.3	VDC
PD	Power Dissipation			1	W
Tst	Storage Temperature	-55		+90	°C
Tj	Junction Temperature	-45		+125	°C
Ilu	Latch up current			+100	mA
Vesd	Electrostatic Discharge – Human Body Model			±2000	V

Stresses at or above those listed in this table may cause permanent damage to the device. This is a stress rating only and functional operation of the device at these or any other condition above those indicated in the following tables is not implied. Exposure to absolute maximum rated conditions for extended periods may affect device reliability (except for the reverse bias condition. See below). Prolonged exposure to high temperatures will shorten the luminance half-life.

Table 6-2 : Recommended Operating Conditions

Symbol	Parameter	Min	Typ.	Max.	Unit
VDD	Front End Power Supply	2.375	2.5	2.625	VDC
VAN	Array Power Supply	4.75	5	5.25	VDC
VCOM	Common electrode bias	-5	-2.0	0	VDC
VPG	Array Bias Supply	-3	-1.5	0	VDC
Tst	Storage Temperature	-55		+90	°C
Ta	Ambient Operating Temp.	-45	+25	+70	°C
Pdt_color ⁽¹⁾	Power Consumption Color Display	88	125	185	mW
Pdt_mono ⁽²⁾	Power Consumption Monochrome White Display	51	60	70	mW

(1) & (2)

- Minimum power consumption is for an all pixels off display condition at room temperature
- Typical power consumption is for an all pixels on display condition at 80 cd/m² (color or monochrome) at room temperature
- Maximum power consumption is for an all pixels on display condition at 200 cd/m² (color or monochrome) at room temperature

Table 6-3 : DC Characteristics

(Ta = 25°C, VDD = +2.5V, VAN = +5V, GND = 0V)

Symbol	Parameter	Min	Typ.	Max.	Unit
VDD	Front End Power Supply		2.5		V
VAN	Array Power Supply		5		V
VCOM	Common electrode bias	-5	-2.0	0	V
VPG	Array Bias Supply		-1.5		V
Vil	Digital input low level	GND-0.3		1	V
Vih	Digital input high level	1.8		VDD+0.3	V
Vol	Digital output low level			0.5	V
Voh	Digital output high level	2.4			V
Vsl	Hsync, Vsync input low	GND-0.3		1	V
Vsh	Hsync, Vsync input high	1.8		VDD+0.3	V
VGN	Gamma feedback signal	0		5	V
Ipix	Average Pixel Current per frame	0	6	15	nA
Ipix_dnl ⁽¹⁾	Average Pixel Current Differential Non Linearity			1	%

(1) Assumes a gamma corrected display with a nominal gamma of 1.0

Table 6-4 : AC Characteristics

(-45°C < Ta < +70°C, GND = 0V, VDD= +2.5V, VAN = +5.0V,
VCOM = -2V, VPG = -1.5V, Ipix_avg = 6 nA)

Symbol	Parameter	Min	Typ.	Max.	Unit
SCLK	Video Clock Frequency	12	-	50	MHz
CLK Duty	SCLK duty cycle	40		60	%
Fhs	Horizontal Sync frequency	15.734		80	KHz
Fvs	Vertical Sync Frequency	30		120	Hz
Tlo	Line Overscan (% of line time)	3			%
Tfb	Frame Blanking (% of frame time)	1			%
Trst	Reset Pulse Width	100		-	µs
Cin	Digital Pins Input Capacitance		3		pF
Cvpg	Pin VPG Input Capacitance		13.6		nF
Pd VAN	Average Van Power Consumption (VGA Mode 60 Hz refresh rate)		80		mW
Pd VDD	Average VDD Power Consumption (VGA Mode 60 Hz refresh rate)		8		mW
Pd VPG	Average VPG Power Consumption			1	mW
Pd PDWN	Total Power Consumption in PDWN (sleep) mode*		2.5		mW
Ta	Ambient Operating Temperature	-45		+70	°C

*Note: Input data, sync and clock lines must be inactive and held low

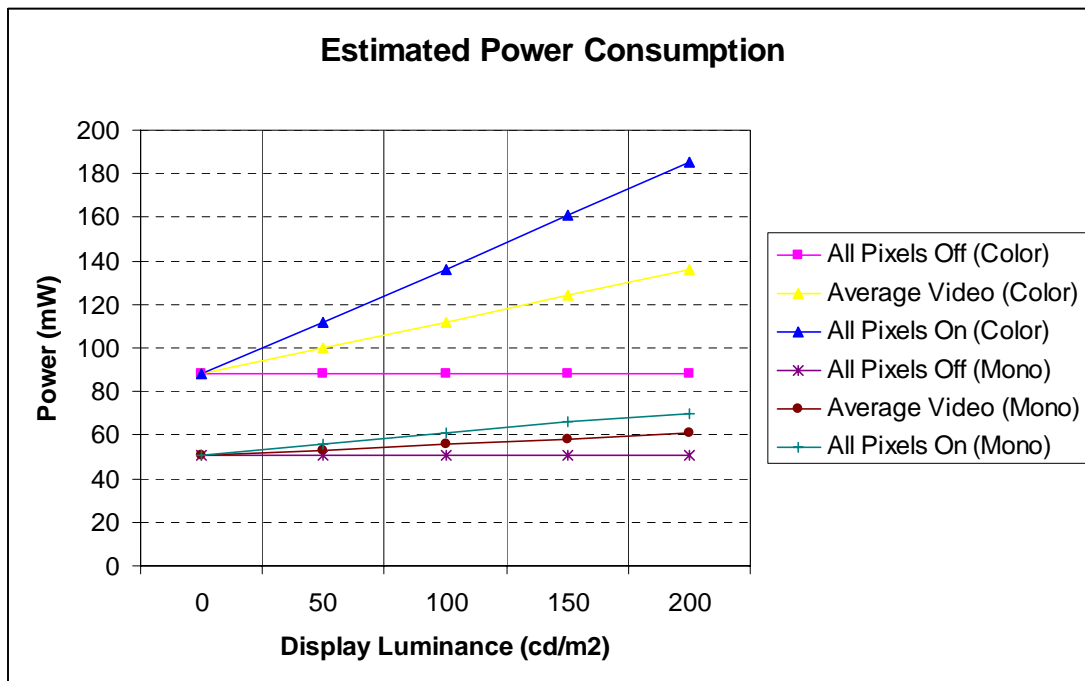

Figure 2 : Total estimated power consumption vs. luminance at 20°C

6.1 Timing Characteristics

6.1.1 Interface Timing Diagrams

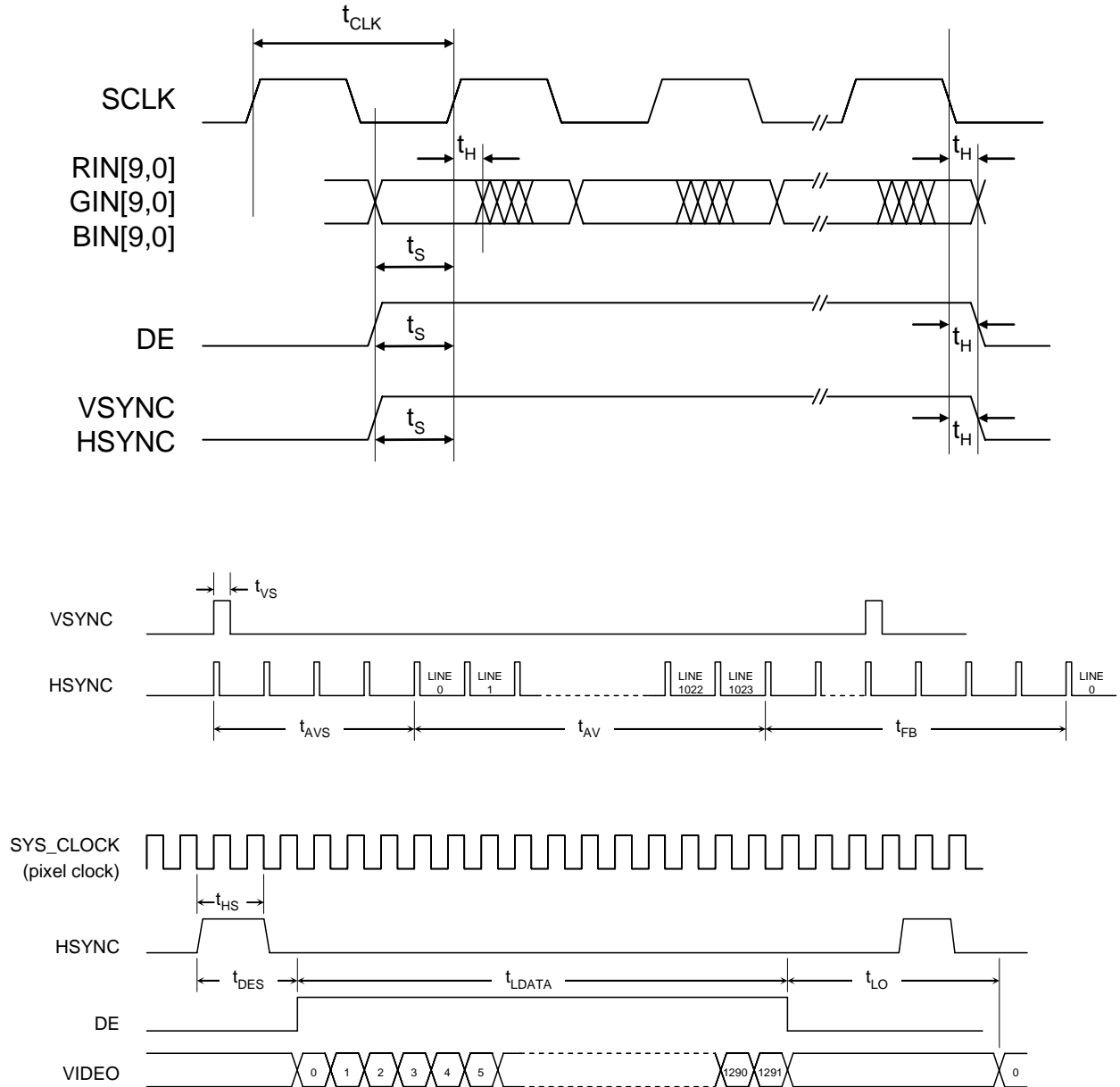

Table 6-5 : Input Timing Characteristics

Parameter	Symbol	Min.	Typ.	Max.	Unit
Video Input Setup/Hold (RIN/GIN/BIN)	t_s	4			ns
	t_H	1			ns
Control Signals Setup/Hold (DE/HSYNC/VSYNC)	t_s	4			ns
	t_H	1			ns
Clock Frequency	f_{CLK}		25.175 ¹		MHz
Clock Period	t_{CLK}		39.72		ns
Clock Duty	D_{CLK}	45		55	%
VSYNC Pulse Width	t_{VS}	1			Hsync period
Time to Active Video Start	t_{AVS}	4			Hsync period
Frame Blanking (% of frame time)	t_{FB}	1			%
HSYNC Pulse Width	t_{HS}	4			SCLK period
Time to DE Start	t_{DES}	12			SCLK period
Line Overscan (% of line time)	t_{LO}	3			%

Note 1: VGA @ 60Hz frame rate

6.1.2 Gamma Sensor Timing Diagram

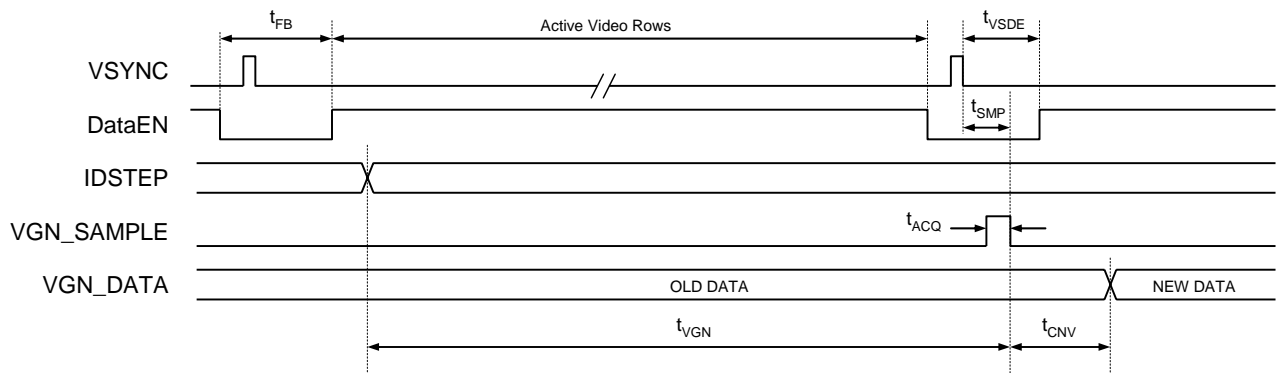

Table 6-6 : Gamma Sensor Timing Characteristics

Parameter	Symbol	Min.	Typ.	Max.	Unit
IDSTEP to VGN Settling Time	t_{VGN}	10			ms
Frame Blanking (% of Frame Time)	t_{FB}	1			%
VGN Sampling Time	t_{SMP}	t_{ACQ}		t_{VSDE}	
A/D Acquisition Time	t_{ACQ}	20			μ s
A/D Conversion Time	t_{CNV}				

7. OPTICAL CHARACTERISTICS

Table 7-1 : VGA XL Color Microdisplay Optical Characteristics

Conditions: Ta = +20°C, VDD = +2.5V, VAN = +5V, VPG = -1.5V, VCOM = internally generated

Symbol	Parameter	Min.	Typ.	Max.	Unit
LMAX	Front Luminance @ max gray level	0.01 ⁽¹⁾	140	400	cd/m ²
CR	White to Black Contrast Ratio	1,000:1			
CIE White	CIE-X	0.27	0.32	0.37	
	CIE-Y	0.32	0.34	0.38	
GL	Gray Levels Per Color	256		1024	levels
F _R	Refresh Rate	30		120	Hz
FF	Emissive Area/Total Sub-pixel Area		0.69		
U _{LA}	End to end large-area uniformity	85 ⁽²⁾			%
S _{VH}	Pixel spatial noise at ½ luminance (1STD)			5	%
S _{LOT}	Peak-to-peak luminance variation over operating temperature range			8 ⁽³⁾	%
T _{ON}	Time to recognizable image after application of power			0.5	sec

Note 1: Minimum dimming level obtained when using the ROWRESET (05h) function.

Note 2: At 100% of gray level brightness and 80 cd/m² luminance. Luminance uniformity measured between the nominal values of five 1000 pixel zones located in the four extreme corners and the center zone of the display.

Note 3: With firmware providing temperature control of DAOFFSET setting

Table 7-2 : VGA XL Monochrome White Microdisplay Optical Characteristics

Conditions: Ta = +20°C, VDD = +2.5V, VAN = +5V, VPG = -1.5V, VCOM = internally generated

Symbol	Parameter	Min.	Typ.	Max.	Unit
LMAX	Front Luminance @ max gray level over dimming range (IDRF, DIMCTL)	0.03 ⁽¹⁾	900	1800	cd/m ²
CR	White to Black Contrast Ratio	1,000:1			
CIE White	CIE-X	0.27	0.32	0.37	
	CIE-Y	0.32	0.34	0.38	
GL	Gray Levels Per Color	256		1024	levels
F _R	Refresh Rate	30		120	Hz
FF	Emissive Area/Total Sub-pixel Area		0.69		
U _{LA}	End to end large-area uniformity	85 ⁽²⁾			%
S _{VH}	Pixel spatial noise at ½ luminance (1STD)			5	%
S _{LOT}	Peak-to-peak luminance variation over operating temperature range ⁽³⁾			8	%
T _{ON}	Time to recognizable image after application of power			0.5	sec

Note 1: Minimum dimming level obtained when using the ROWRESET (05h) function.

Note 2: At 100% of gray level brightness and 80 cd/m² luminance. Luminance uniformity measured between the nominal values of five 1000 pixel zones located in the four extreme corners and the center zone of the display.

Note 3: With firmware providing temperature control of VDACMX setting

8. MECHANICAL CHARACTERISTICS

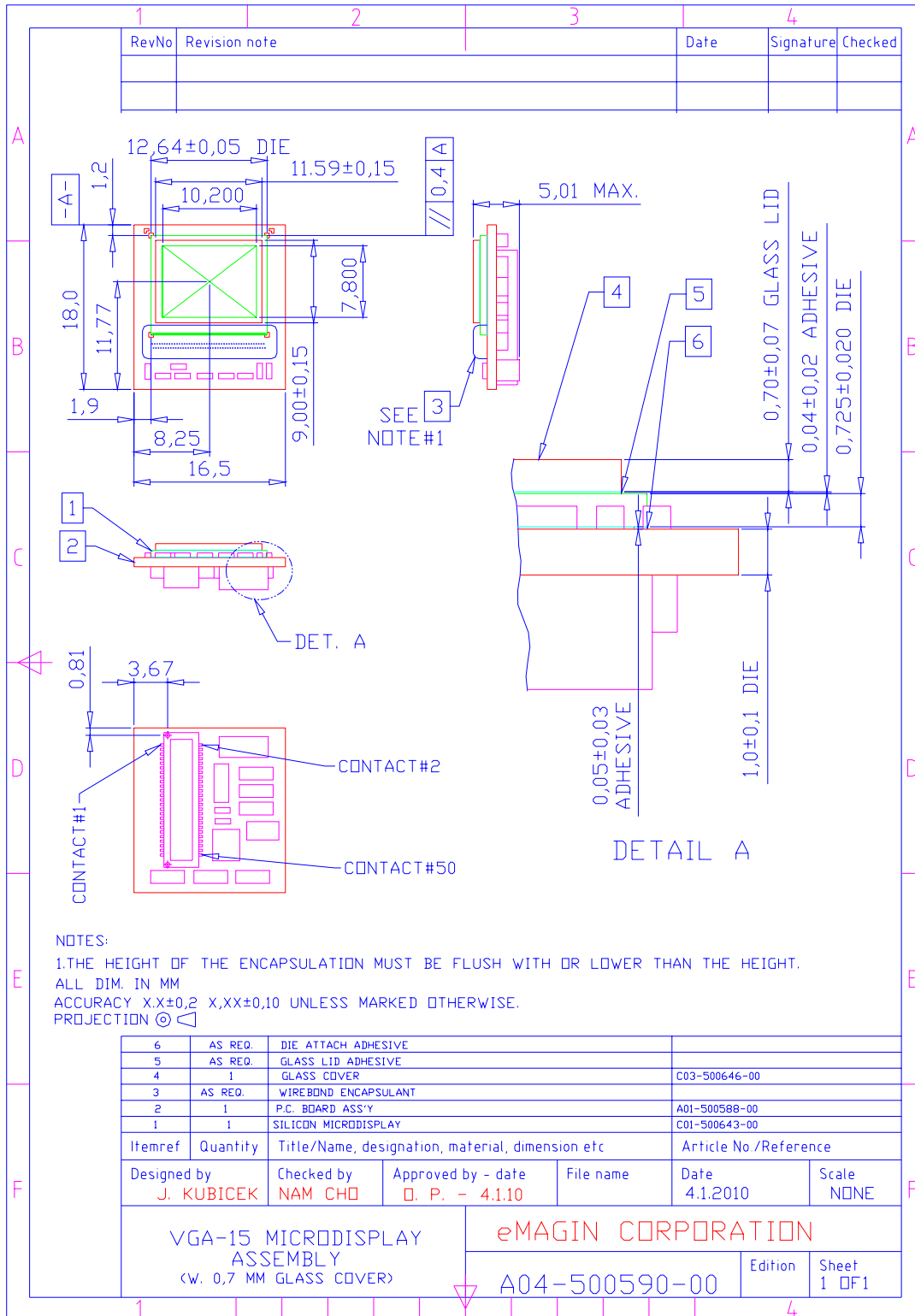

Figure 3: Color VGA Microdisplay IC Drawing with 0.7mm Glass Cover

8.1 Color VGA Configuration

Connector J1

Manufacturer: Hirose
Manufacturer Part Number: DF12D(3.0)-50DP-0.5V

Mating Connector Information

Manufacturer: Hirose
Manufacturer Part Number: DF12A(3.0)-50DS-0.5V
Weight: < 2 grams

Printed Circuit Board Material: FR4
Printed Circuit Board Tolerances: ± 0.3 mm (both axes)

8.2 Monochrome VGA Configuration

Connector J1

Manufacturer: Hirose
Manufacturer Part Number: DF12D(3.0)-30DP-0.5V

Mating Connector Information

Manufacturer: Hirose
Manufacturer Part Number: DF12A(3.0)-30DS-0.5V

Weight: < 2 grams

Printed Circuit Board Material: FR4
Printed Circuit Board Tolerances: ± 0.3 mm (both axes)

9. DETAILED FUNCTIONAL DESCRIPTION

9.1 Video Input Interface

The 30-bit digital input port is comprised of three 10-bit data busses that make up the RGB data inputs. Separate synchronization signals (VSYNC and HSYNC) and the pixel clock (SCLK) are to be provided by the external video source. The data valid signal (DE) is used to signal the start of loading a row of data into the internal line memory. An active ENABLE signal is required for the Stereovision mode (inactive for all other modes, except Interlaced Video). The timing diagram for the input data bus is shown in Figure 4.

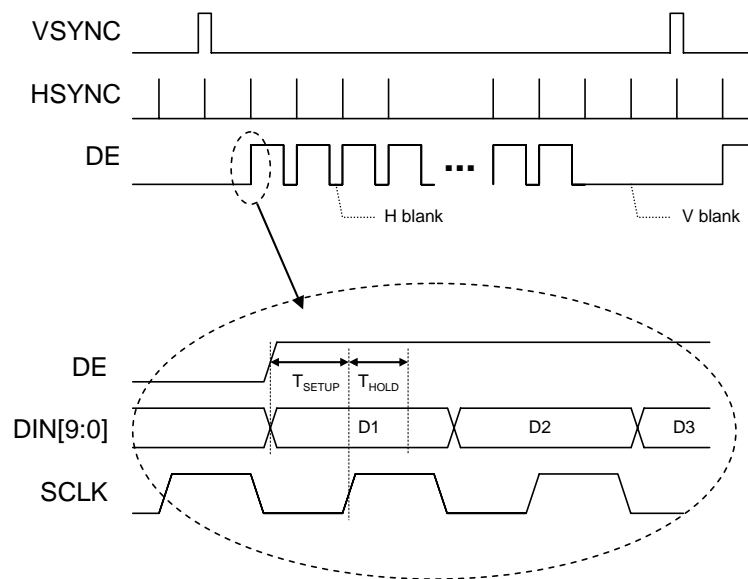

Figure 4 : Input Data timing diagram.

The input data to the display requires certain formatting that must be applied by the external drive electronics as described below.

9.1.1 Gamma Correction

Due to the non-linear electro-optic characteristic of the OLED pixel, a gamma correction signal must be applied to the video input signal to achieve a linear system response for the display. Since the optimum gamma curve will vary with temperature and luminance, it should also be regularly updated to account for changes in operating conditions. The color balance for the display can be modified by controlling the gamma individually for each of the three color data channels. The typical OLED response to input data is a highly nonlinear characteristic. The Gamma Correction function shown in Figure 5 is obtained by

inverting the OLED response function. The overall system display response becomes linear when the source video data is modified by the Gamma Correction function before being applied to the VGA.

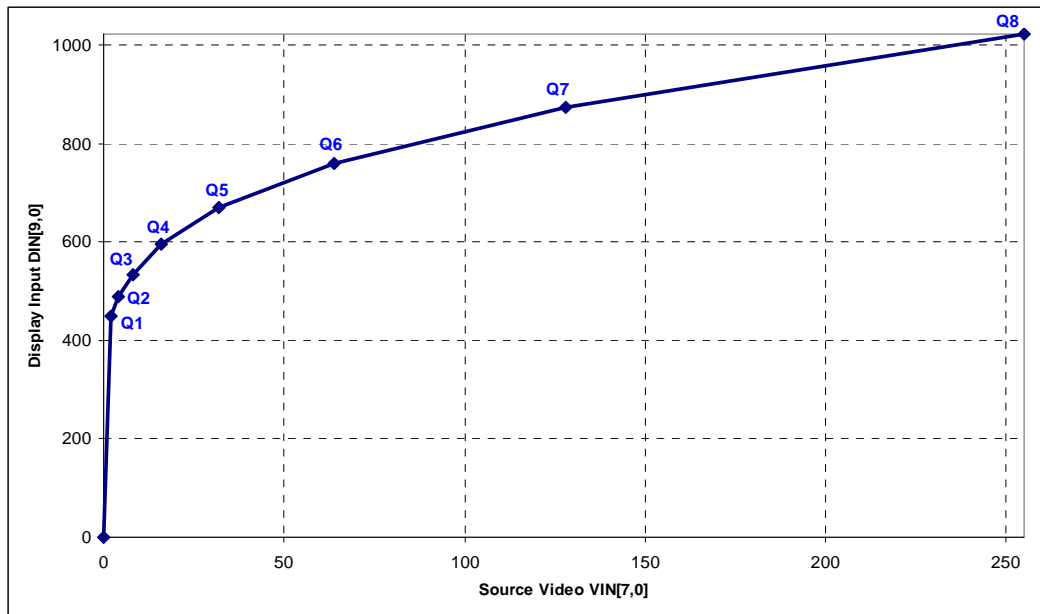

Figure 5: Typical VGA input transfer function

As shown in Figure 6, a typical VGA application will include a 256x10-bit look-up-table for each color channel located in the data path between the video source and the display. The LUT, which is contained in an external FPGA, converts the 8-bit data byte for each color of the video source into a 10-bit output data word for driving the microdisplay. The LUT is programmed with the gamma correction function required to linearize the system for the current operating conditions. Due to the non-linear characteristic of the OLED display, a 10-bit input to the VGA is used to ensure a linear 8-bit optical response with better than 1-lsb accuracy.

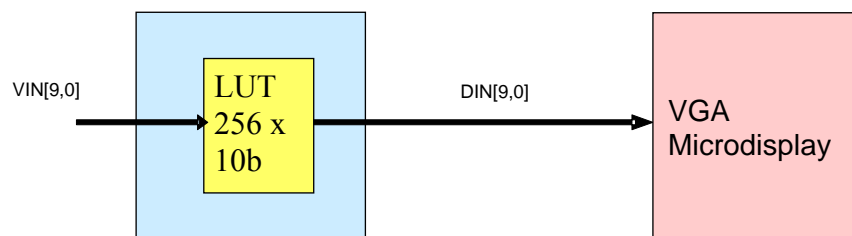

Figure 6: Gamma correction using a look-up table (LUT)

On-chip support for generating the gamma correction function in the form of an 8-segment piecewise-linear function is described in section 9.4.6. A total of 8 data points (Q1...Q8) that lie on the gamma curve as shown in Figure 5 are provided by the display chip. The external microcontroller can use this information to generate intermediate data points for the entire 256 point curve by linear interpolation.

9.1.2 Row Data Expansion

Since the display is comprised of 680 column lines, the external drive electronics should add 20 dummy pixels with black data to each row of 640 pixels provided by the source signal. The dummy pixels can be distributed between the start and end of the row data according to the desired horizontal location of the active window within the pixel array.

9.2 D/A Conversion

In this design the conversion of the video input signal into an analog drive signal at the pixel is carried out in a two step process during each horizontal clock period. The digital input video data is first transformed into a precise time delay based on counts of the global RAMP clock. Second, the time delay triggers the column switch to sample the voltage of a linear ramp and to store the analog value on the column line capacitor. The selected pixel circuit copies the analog data and uses it for driving the OLED diode until it is refreshed during the next frame period.

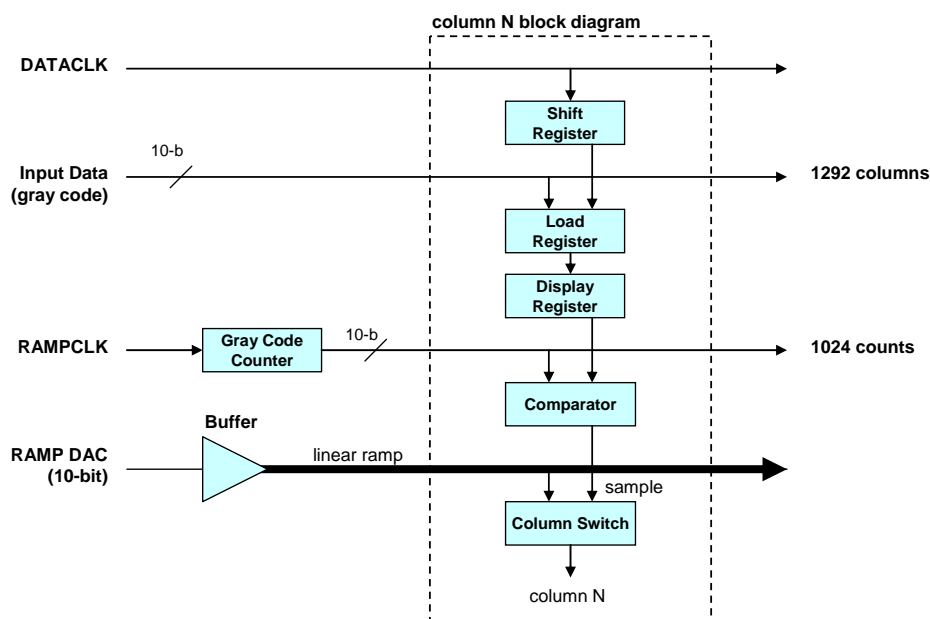

Figure 7 : Data sampling for Column N

A block diagram of one column drive circuit is shown in Figure 7. The 680 Display registers form a line memory that facilitates a pipeline mode of operation in which video data is converted to analog form and sampled by the pixels in row M during the same line period that video data for row M+1 is loading into the LOAD registers. At the end of each line period the data in the LOAD registers is transferred in parallel into the DISPLAY line memory. The externally supplied SCLK clock is used for both loading input data into the chip and for advancing the global column counter. There is a maximum latency of 2 line periods before data is displayed.

A timing diagram for the data sampling process is shown in Figure 8. The internal Ramp Generator operates at the HSYNC frequency and outputs a linear ramp with a slow rise-time and a fast reset capability that is buffered and applied to all the pixel array columns simultaneously. The RAMP signal starts synchronously with HSYNC (after a delay) with a positive slope from a zero voltage level and rises to a voltage near the VAN rail after 480 SCLK clock cycles as determined by a 10-bit counter. The start position of the RAMP can be adjusted via bit RAMPDLY in register RAMPCTL, its peak value can be set using register VDACMX, and the duration of the flyback transition can be selected between two options by the FLYBTIME bit in register RAMPCTL.

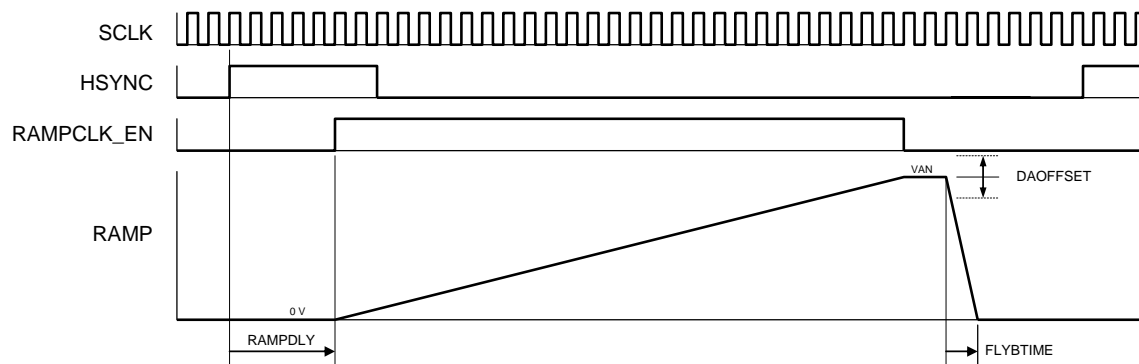

Figure 8 : Timing diagram for column data sampling

9.3 Format and Timing Control

Various control signals for the horizontal and vertical sequencers that are needed to implement the specified video formats are generated in the Timing & Control Logic block. The specific timing parameters are set by registers VINMODE, DISPMODE, TOPPOS, and BOTPOS using the serial interface.

The display starts up with the array in the off-state (black) by default and requires a command to the DISPOFF register bit via the serial interface to turn the display on. This provides the user with an opportunity to change the default startup conditions before the display lights up.

Bi-directional scanning is supported in both orientations via the DISPMODE register. Bit VSCAN sets the vertical scan direction, and bit HSCAN sets the horizontal scan direction.

Selection among the main supported display formats is done via register bits TOPPOS, BOTPOS, and the external drive electronics. The starting row is determined by register TOPPOS and the ending row by register BOTPOS, which are set by default so the active window in VGA mode is vertically centered in the array. These registers allow the active window to be shifted vertically in 1 pixel steps by up to 20 pixels.

The starting column is determined by the external drive electronics which must add 20 dummy black pixels to each row of incoming data as described previously. This allows the active window to be horizontally shifted in 1 pixel steps by up to 20 pixels total.

9.3.1 Interlaced Mode

Bit SCMODE in the DISPMODE register is used to select either progressive or interlaced mode for all formats. By default (SCMODE=0) the normal progressive mode is active. The interlaced mode is limited to a maximum of 512 and a minimum of 240 active rows per field.

Field status in interlaced mode is provided via the ENABLE input pin. The state of this pin is latched on the falling edge of VSYNC. When register bit SET_FIELD = “0” then a logic low at the ENABLE pin indicates that Field 1 (odd field) is active, and a logic high indicates that Field 2 (even field) is active. The opposite states are indicated when SET_FIELD is set to 1.

9.3.2 Stereovision

The VGA is designed with binocular stereovision applications in mind. As a result of the fast OLED response time and the presence of a storage capacitor at each pixel, the microdisplay can operate at low refresh rates without showing flicker.

This will allow the displays to be used with a frame or field sequential (more generally know as time sequential) stereovision mode using a single video input channel, and therefore providing a simple means to leverage the capabilities of PC compatible computers using stereo compatible graphics adapters, such as the Nvidia GeForce series. The frame sequential stereovision mode supported should follow the Video Electronics Standards Association (VESA) Connector and Signal Standards for Stereoscopic Display Hardware. This standard is available from VESA at www.vesa.org.

The ENABLE input pin will allow for a direct implementation of the VESA standard without additional external components. The microdisplay can be programmed for either an active high or low Enable, allowing a single signal to be used with two displays. In such a configuration, one display scans and displays while the other one holds and displays.

The ENABLE input acts, when set low, as a mask for HSYNC and VSYNC. It does not blank the display but prevents it from acquiring another frame of data until released. This is a real time input. The active state (high or low logic level) is programmed by the SET_ENABLE bit in the VINMODE resister.

The 3D-MODE bit of the DISPMODE register will be used to set either the Stereovision mode of operation (1) or Normal (non-3D) operation (0).

Frame Sequential Mode:

In Time Sequential Mode each video frame contains information for either the left or right eye. When 3D-MODE="1" the SCMODE bit in the DISPMODE register is set to Progressive Scan Mode (00H) for frame sequential mode. The following description for Frame Sequential operation assumes the source is in compliance with the VESA standard mentioned above, where the data for the left eye is provided while the Enable signal is at the logic high level, and the data for the right eye display is provided while the Enable signal is at the logic low level. The stereovision mode is controlled by both the Enable input pin and by the SET_ENABLE bit of the VINMODE register. The Enable input signal is sampled into the circuit by a flip-flop clocked on the falling edge of VSYNC and the sampled value will be used for the next frame. (The Enable signal is generated by the graphics software and may not be synchronized to the VSYNC signal).

To activate the stereovision mode, the right eye display needs to be configured with Enable active low (SET_ENABLE="0"). This will allow the right eye microdisplay to hold the previous frame while the Enable input is high. The left eye display must be configured with Enable active high (SET_ENABLE="1"). Thus the two Enable inputs can be tied together to the incoming Stereo Sync signal provided by the graphics adapter (or other custom source). This is illustrated by the timing diagram shown in Figure 8.

Line Interleaved Mode:

In Line Interleaved Mode each video frame contains information for both the left and right eyes. Consequently, the resolution is reduced in half for each display but they both run at the full frame rate. The operation of the Enable input pin and the SET_ENABLE bit will be similar to Frame Sequential Mode except that now the Enable input toggles at the line rate.

For standard VGA operation, the SET_ENABLE bit needs to be set to 0 (logic low), which is the power-on default value, and the Enable pin input needs to be tied to Ground.

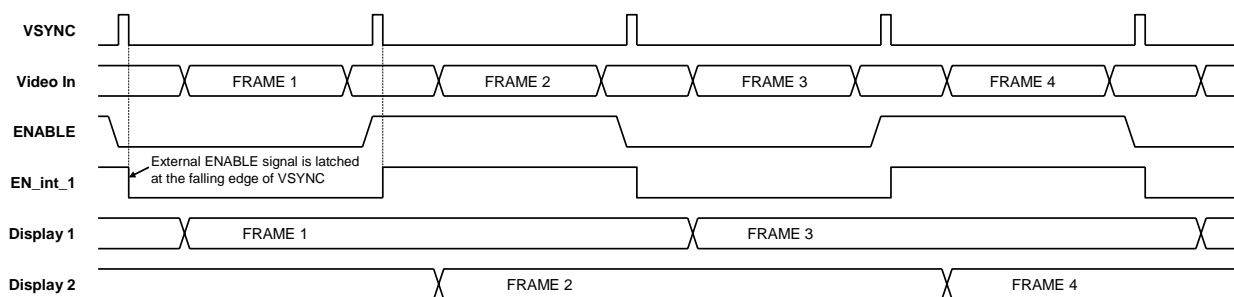

Figure 9: Timing for frame sequential stereovision mode

9.4 Sensor Functions

9.4.1 Temperature Readout

An on-chip temperature sensor provides continuous device temperature information via the serial interface. The sensing circuitry allows for calibration at power-up via dedicated registers, TREFDIV[5,0] and TEMPOFF[7,0]. The temperature reading is digitized on-chip and stored in a dedicated register, TEMPOUT[7,0]. A register bit, TSENPD in register ANGPWRDN, is able to power down the sensor.

The temperature sampling period is controlled by register TUPDATE[7,0] which allows the temperature reading to be updated between every 50msec to 4.25sec when operating at a 60Hz frame rate.

9.4.2 Luminance Regulation Sensor

Register VGMAX[7,0] controls the pixel drive voltage used for regulating the maximum luminance value. By default this level is set to about 4.95V when the VAN supply is equal to 5V to avoid saturating the video buffers. It can be adjusted over a range of 4 to 5V.

Register VDACMX[7,0] is used to set the maximum value of the internal Ramp DAC generator. This value should match the internal VGMAX setting for best luminance accuracy and control. The optimum setting can be derived by measuring luminance for different values of VDACMX as described in 11.9.

9.4.3 Pixel Bias Sensor

Register BIASN[1,0] sets a bias current for the OLED array in order to achieve improved control of black level and color saturation at the expense of a small increase in power consumption. In the default setting (BIASN=1) the bias contributes to a 10mW increase of power consumption for the array. It is recommended to use the BIASN=1 setting for best performance.

9.4.4 Luminance Control (Analog Dimming)

A variable luminance level is achieved by controlling the maximum pixel current while maintaining the largest possible dynamic range. Dimming control for the display is effected by adjusting the 7-bit register DIMCTL via the serial interface to provide 128 linear steps in brightness ranging from near zero to the maximum level set by register IDRFB. This functionality is only available for VCOMMmode=0 or 1.

The bits IDRFB_COARSE in register IDRFB provide a coarse adjustment of the maximum luminance level, while the IDRFB_FINE bits enable the coarse level to be fine tuned. Figure shows the typical luminance levels in a color display for various settings of the IDRFB register when DIMCTL is set for maximum brightness.

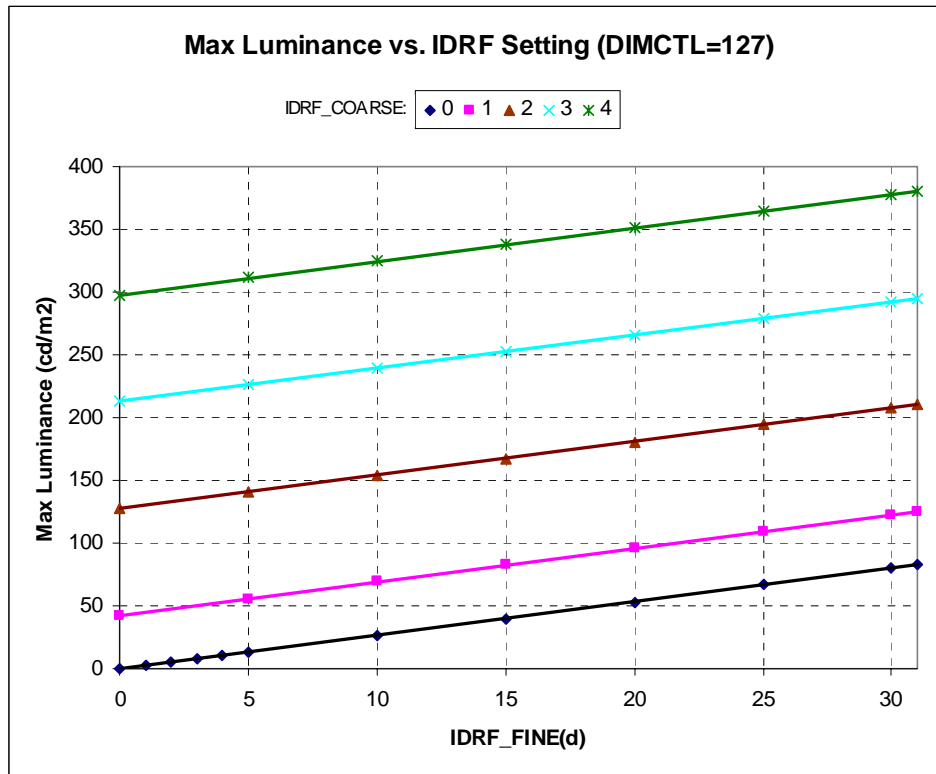

Figure 10: Typical maximum luminance for various IDRf settings

9.4.5 Luminance Control (PWM Dimming)

A variable luminance level can also be achieved by setting the frame on-time of the video image using register ROWRESET (05h). This register controls the fraction of a frame period during which the input video data is displayed (on-time). The display is set to black for the off-time or non-display portion of the frame period as shown in Figure 11.

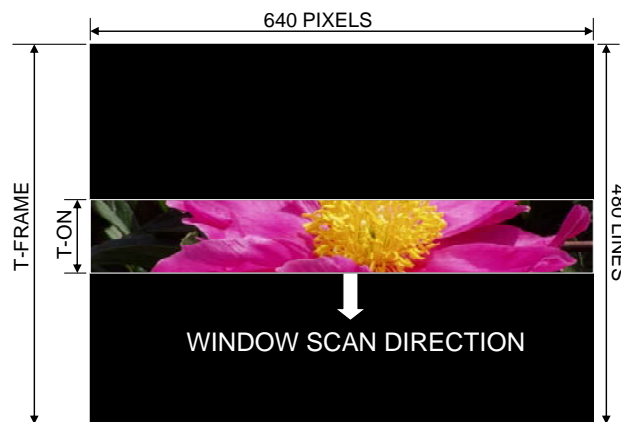

Figure 11: Video display during PWM dimming control

PWM dimming via ROWRESET can be used in combination with the analog dimming function to achieve an extended luminance control range since both modes operate independently. For any luminance level achieved via the IDRF and DIMCTL settings, the ROWRESET function will enable the luminance to be varied over a range of 0.4 to 100%.

9.4.6 Gamma Correction Sensor

The gamma sensor is provided as an aid to generating a linear optical response from the SXGA display system. As described previously, an external 256-entry look-up-table is required to transform input video data into a gamma-corrected data signal for driving the microdisplay input port. The SXGA display generates an internal real-time representation of the gamma correction curve for the current operating conditions. This representation is in the form of an analog voltage waveform which can be sampled one point at a time at the VGN pin for eight specific values on the curve. A specific value VGN_i , corresponding to one of 8 internally fixed grayscale levels GL_i , is selected by setting bit IDSTEP in register GAMMASET via the serial port. The VGN signal can be set for a full-scale output range of either VAN (default) or VAN/2 by setting bit VGNSH_EN in register GAMMASET. Eight sequential measurements are required to complete the gamma table. The gamma table can then be used to reconstruct an approximation of the ideal gamma correction curve using piece-wise linear interpolation, or by employing a curve fitting algorithm to achieve more accuracy if desired. This function is only available for VCOMMmode=00h.

An external A/D converter is required to convert each VGN measurement into digitized form and to store the values in a microcontroller for further processing. A full frame period following a change in the IDSTEP bit should be provided to allow the VGN signal to settle before sampling it to 10-bit precision by the external A/D converter. It is recommended to sample the VGN signal during the frame blanking interval for best results.

The VGN readings are normalized and converted to a 10-bit full-scale word $DVGN_i[9,0]$ using the following expression:

$$DVGN_i[9,0] = \frac{VGN_i}{VGN_{MAX}} * 1023$$

where VGN_{MAX} is either VAN or VAN/2 as determined by bit VGNSSEL. Each of these data values must be further multiplied by a correction factor CF_i to obtain the Gamma table coefficients as follows:

$$GC_i[9,0] = DVGN_i * CF_i$$

where the empirically determined values for factor CF_i are given in Table 9-1.

Table 9-1: Correction Factor values

CF1	CF2	CF3	CF4	CF5	CF6	CF7	CF8
0.844	0.873	0.893	0.917	0.940	0.959	0.976	1

Using the derived values for GC_i and their corresponding grayscale coordinates GL_i , the 8-entry Gamma Correction table consisting of data points $Q_i = (GL_i, GC_i)$ can be constructed. The outcome of a typical gamma sensor measurement and calculation procedure is shown in Table 9-2.

Table 9-2: Sample Gamma Correction Table

i	1	2	3	4	5	6	7	8
$IDSTEP[0]$	0h	1h	2h	3h	4h	5h	6h	7h
$VGN_i(volt)$	1.839	1.876	1.913	1.964	2.045	2.159	2.318	2.500
$GC_i(dec)$	662	698	727	766	814	872	941	1023
$GL_i(dec)$	2	4	8	16	32	64	128	255

The full 256-word LUT is derived from the Gamma Coefficient Table using linear interpolation to generate intermediate data points as illustrated in Figure 12. The input to the LUT for each color of the video source is represented by the 8-bit signal $VIN[7,0]$, and the output of the LUT (which is also the input to the microdisplay) is represented by the 10-bit signal $DIN[9,0]$. For example, the Y coordinate for the intermediate point $Q(x, y)$ on the line segment formed between the gamma table points Q_6 and Q_7 is obtained by:

$$Y = Y_6 + (Y_7 - Y_6) * \frac{(X - X_6)}{(X_7 - X_6)}$$

The intermediate points for other line segments are found in similar fashion. A software routine in the system microcontroller is used to perform the necessary calculations. The software is also used to convert the LUT data into Gray Code format before loading it into the data-path LUTs in the FPGA. A buffer LUT should be used in the FPGA to temporarily store the data as it is transferred from the microcontroller via the serial port. When the buffer LUT is full, the data can be rapidly transferred to the data-path LUTs during a frame blanking time to avoid disturbing the displayed image.

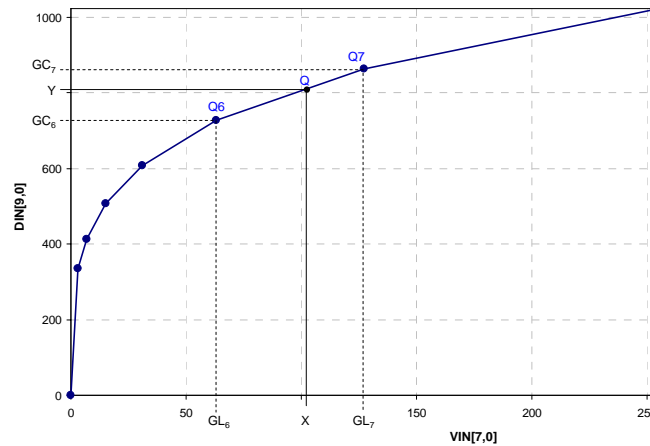

Figure 12: Gamma curve generated using PWL function

9.5 DC-DC Converter

An on-chip dc to dc converter controller allows for the generation of the OLED cathode supply, relying on a few external passive components assembled on the display carrier board. The converter is an adjustable inverter that converts VAN to a negative supply used to bias the OLED via the VCOM input pin. Adjustment is managed by the control logic and registers VCOM[7,0] and VCOMMODE[1,0].

The converter adjustment comes from two sources:

- A nominal value set in a dedicated register that provides for the room temperature voltage level.
- The output of an internal VCOM sensor circuit. This feature can be enabled/disabled via register setting to allow full external control (via register VCOM).

A soft-start function is provided that allows the converter output to ramp up in a controlled fashion by sensing the switch current and limiting its peak value.

A block level schematic of the Cuk converter that is employed in the VGA application is shown in Figure 13.

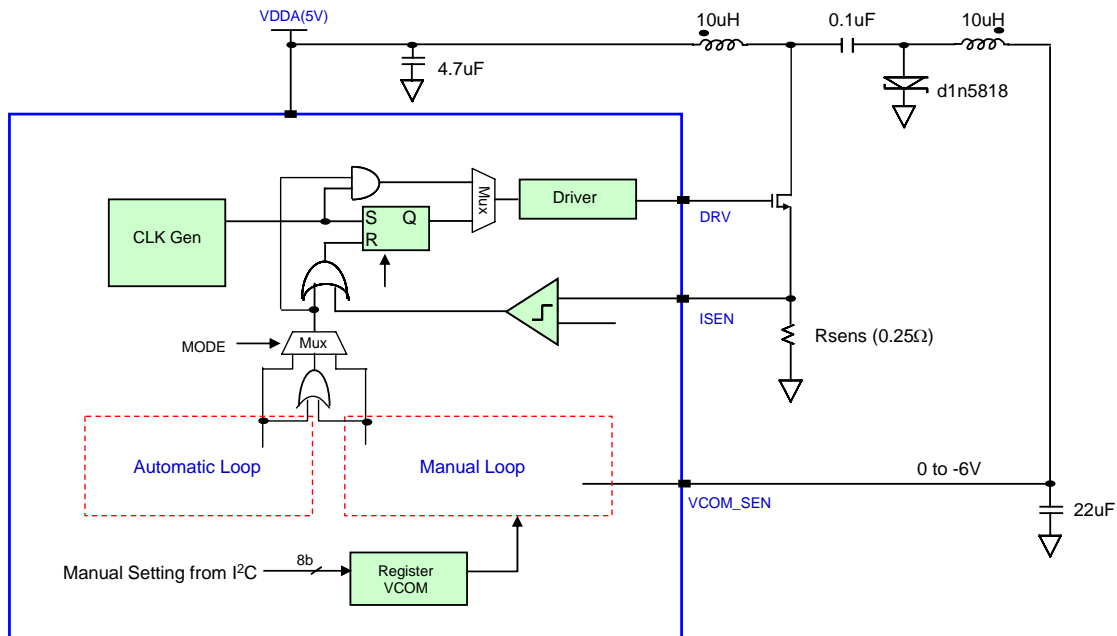

Figure 13 : Schematic of DC-DC controller function

Three modes of operation, selected via register VCOMMODE, are provided for the controller function. Mode 1, selected by default (VCOMMODE=0), activates the Automatic Loop which provides VCOM regulation based on an internal current feedback sensor. In this mode the cathode supply is automatically regulated in order to maintain a constant maximum OLED array current over changes in temperature and luminance. The cathode voltage will tend to rise in absolute value as the luminance level is increased or the operating temperature is reduced.

Mode 2, selected by setting VCOMMODE=1h, is a hybrid control mode that prevents the absolute value of the cathode supply from becoming too small at higher temperatures, but allows it to increase at low temperatures where it is needed to ensure a stable regulated OLED current. Both the AUTO and MANUAL control loops are running simultaneously in this mode with one taking charge above a user defined threshold (set by register VCOM) and the other below that threshold. For relatively low temperatures and high luminance levels the AUTO mode will be in control and the cathode supply will follow the trajectory shown in Figure 14. If operating conditions try to force the absolute value of the cathode supply to drop below the threshold, then the control switches to MANUAL mode and the regulated supply remains fixed at the VCOM level.

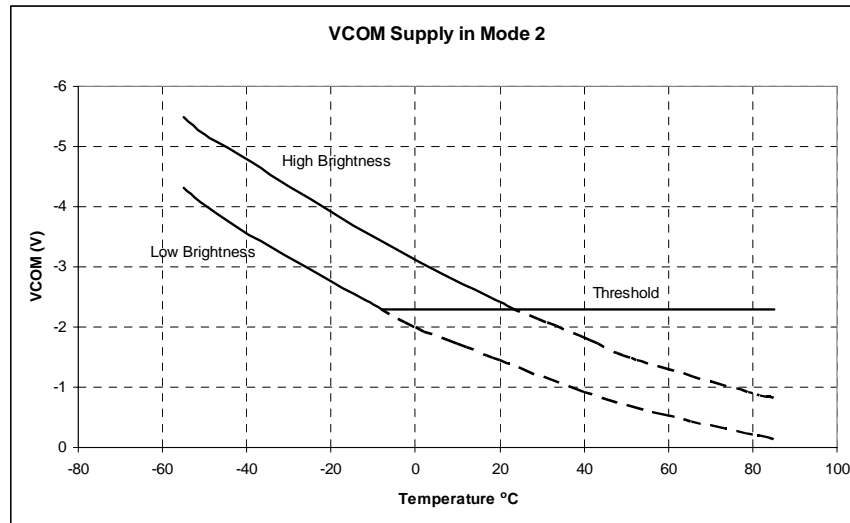

Figure 14 : VCOM supply characteristic in Mode 2

Mode 3, selected by setting VCOMMODE=2h, activates the Manual Loop which provides a fixed cathode supply based on a cathode voltage feedback signal. The actual value of the cathode voltage is controlled over a range of 0 to -6V by setting register VCOM. Its default value is about -2.3V. In this mode the dimming and luminance regulation functions via IDRFB and DIMCTL are not operational. Luminance is controlled directly via the VCOM register setting in this mode instead.

9.6 I²C Serial Interface

The serial interface consists of a serial controller and registers. The serial controller follows the I²C protocol. An internal address decoder transfers the content of the data into appropriate registers. The protocol will follow the address byte followed by register address data byte and register data byte sequence (3 bytes for each register access):

- Serial address with write command
- Register address
- Register data

The registers are designed to be read/write. Read mode is accomplished via a 4 byte sequence:

- Serial address with write command
- Register address
- Serial address with read command
- Register data

RANDOM REGISTER WRITE PROCEDURE

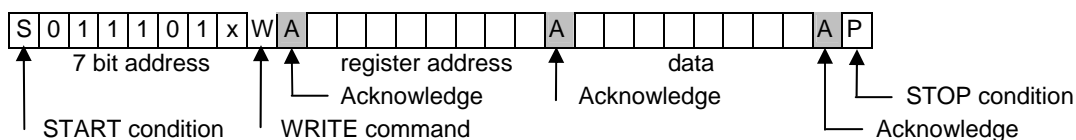

RANDOM REGISTER READ PROCEDURE

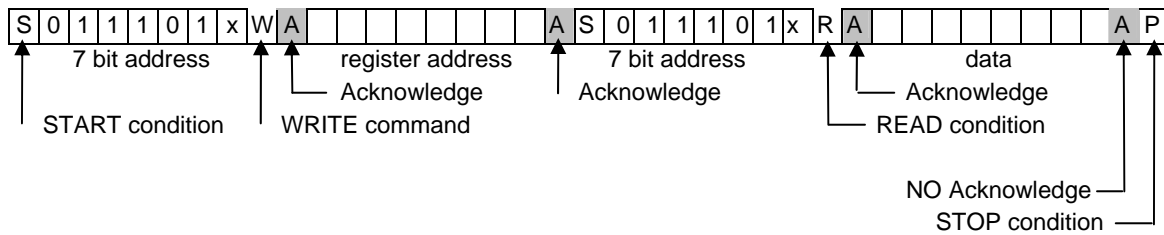

The serial controller is capable of slave mode only.

The x in the 7-bit address code is set by the SERADD input pin and is provided to allow a dual display and single controller configuration.

Slave Address: 011101X where X = 0 or 1 depending on the status of the SERADD pin. This is summarized in Table 9-3.

Write Mode: Address is 74h (or 76h if SERADD = 1)

Read Mode: Address is 75h (or 77h is SERADD=1)

Sequential Read/Write Operation:

The serial controller allows for both sequential and read operational modes. For either mode, the host needs only set the initial register address followed by as many data bytes as needed, taking care not to issue a STOP condition until all desired data bytes have been transmitted (or received).

Maximum interface frequency: 400 KHz.

Table 9-3 : I²C Address Summary

VGA		0	1	1	1	0	1	SA	w/r
SA=0	write	0	1	1	1	0	1	0	0
	read	0	1	1	1	0	1	0	1
SA=1	write	0	1	1	1	0	1	1	0
	read	0	1	1	1	0	1	1	1

9.7 Power-On Sequence

To ensure proper startup and stabilization of the display the following power-on sequence is recommended:

1. Turn on VDD, VAN, and VPG supplies (these can be simultaneous)

2. A ramp-up time of 1 to 40ms for VAN and VDD is recommended for best performance
3. VDD should stabilize at least 1ms ahead of VAN
4. The ramp-up time for VPG is not critical and it can be turned on anytime
5. Configure the display registers to the desired startup state
6. Turn on the display by setting the DISPOFF bit in register DISPMODE to “0”

Figure 15 shows the timing diagram for the power supplies and control signals during startup when the display is first turned on. The external supply voltages (VAN, VDD, and VPG) can all be applied at the same time as in the diagram. An internal reset signal (rstn) is triggered when VDD exceeds a built-in threshold level. After a delay of about 40ms the VAN supply to the array is enabled (VANen). Following an additional 20ms the internal dc-dc controller is activated (VCOMen) which generates a negative supply for the common cathode of the array. The video display is enabled 20ms later (VIDEOen) and video is displayed on the array after the DISPOFF bit has been set to “0” via the serial port. Prior to this moment the pixels in the array are actively driven to the black state. The pin RESETB must also be logic high before any registers can be written.

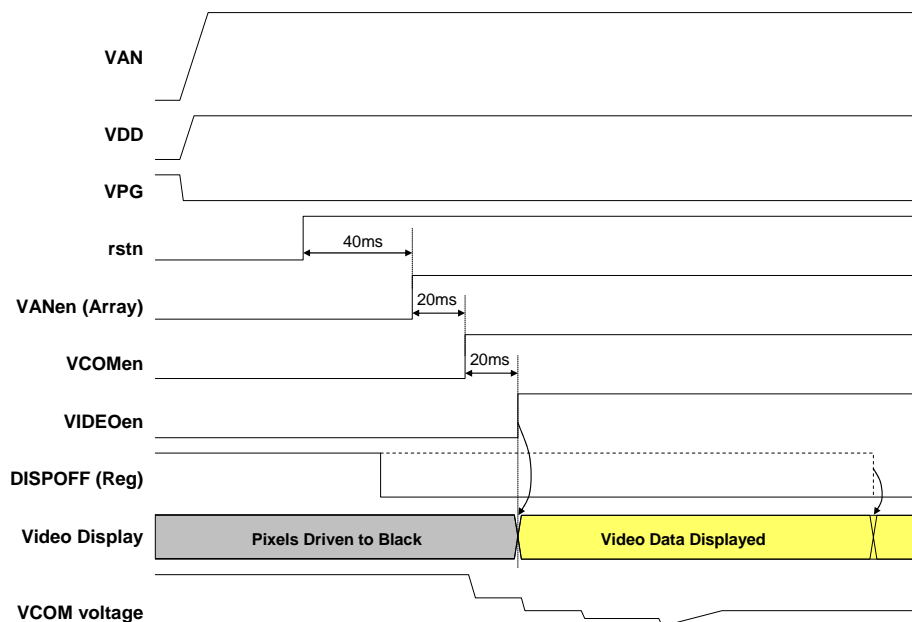

Figure 15 : Power-Up sequence for supplies and control.

NOTE: Do not apply VAN without a VDD supply first. This will result in high current and possible device damage!

The supply currents drawn during a typical startup condition are illustrated in Figure 16.

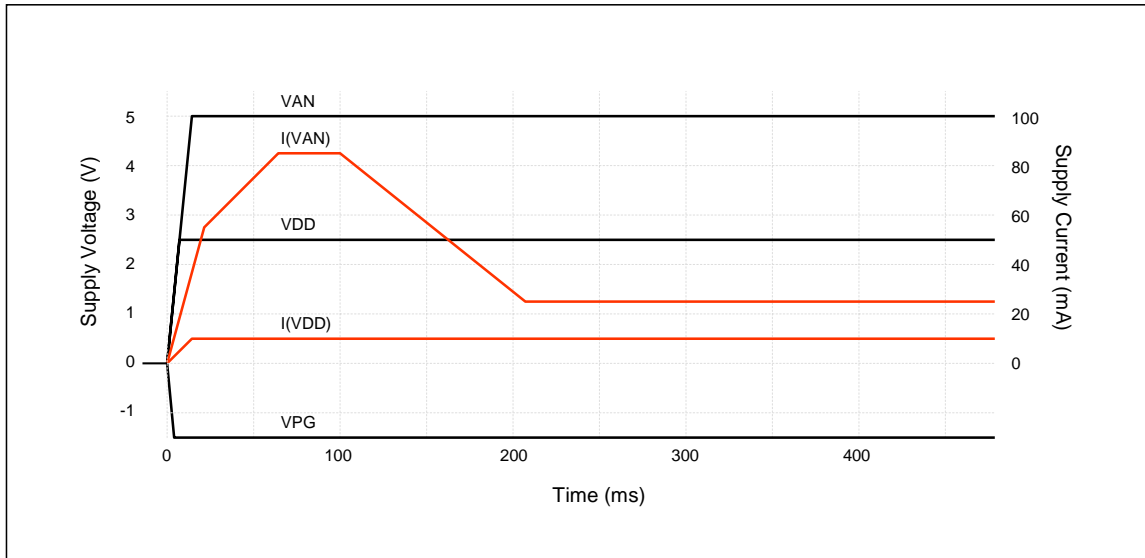

Figure 16: Typical startup currents

9.8 Power-Savings Mode

The display provides power down modes to minimize power consumption. This can occur in two ways:

- Sleep mode – manually controlled via the PDWN bit in register SYSPWRDN, the entire display chip is powered down except for the serial interface. The register settings are saved and restored on power up from this mode.
- Individual block control – several functional blocks have the option to be turned off manually via control of registers ANGPWRDN and SYSPWRDN.

The normal power-down sequence for supplies and control is given in Figure 17, while the power-down/power-on sequence for the sleep mode is shown in Figure 18. The data, sync and clock inputs should be inactive and held low to achieve the minimum sleep-mode power consumption.

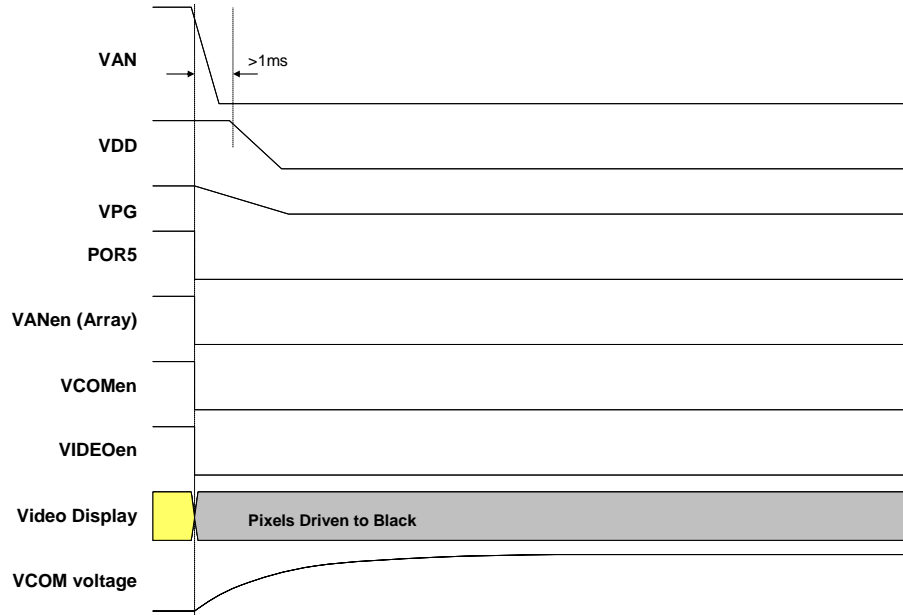

Figure 17: Power-Down sequence for supplies and control.

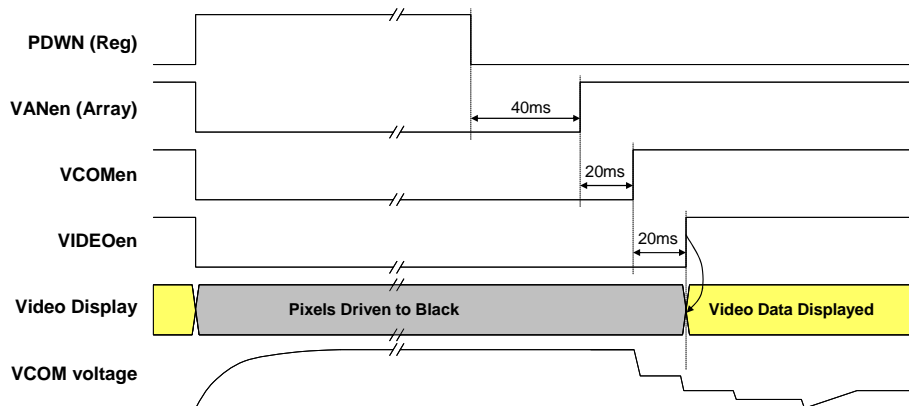

Figure 18 : Soft power-down / power-on sequence for supplies and control.

9.8.1 Display-Off Function

On power-up the microdisplay sets all internal registers to their default values and holds the array in the off state (black) until a software reset is externally applied. The DISPOFF bit in the DISPMODE register must be set to zero via the serial port in order for the array to become active.

10. REGISTER MAP SUMMARY

Address (Hex)	Name	Access	Bit Name	Bit #	Reset Value (Hex)	Description
00	STAT	R	CID	3	-	Chip ID (0 = Mono Display Chip, 1 = Color Display Chip)
			REV	2-0	0	Silicon Revision Number
01	VINMODE	R/W	WRDISABLE	4	0	I ² C Register Write Disable 0 = Write Enable, 1 = Write Protected (All other Regs becomes Read Only)
			SET_ENABLE	3	0	ENABLE Active Level 0 = ENABLE active low, 1 = ENABLE active high
			SET_FIELD	2	0	FIELD Polarity 0 = Odd Field when ENABLE=Active, 1 = Even Field when ENABLE=Active
			VSYNCPOL	1	0	VSYNC Polarity 0 = Negative Sync, 1 = Positive Sync
			HSYNCPOL	0	0	HSYNC Polarity 0 = Negative Sync, 1 = Positive Sync
02	DISPMODE	R/W	DISPOFF	5	1	Display Off (BURNIN mode override to ON) 0 = Display On, 1 = Display Off
			3D-MODE	4	0	3D Display Mode 0 = Normal Display, 1 = Time Sequential Mode
			SCMODE	3-2	0	Progressive or Interlaced scan mode select 00 = Progressive, 01 = Interlaced, 1X = Pseudo Interlaced
			VSCAN	1	0	Vertical Scan Direction 0 = Top to Bottom Scan, 1 = Bottom to Top Scan
			HSCAN	0	0	Horizontal Scan Direction 0 = Left to Right Scan, 1 = Right to Left Scan
03	TOPPOS	R/W		5-0	14	Row Display Top Position
04	BOTPOS	R/W		5-0	14	Row Display Bottom Position
05	ROWRESET	R/W		7-0	0	Row Duty Control (0:Disable, Each line displayed ROWRESET*2 Line period)
06	RAMPCTL	R/W	GCPSAVE	4	0	Global Counter Power Save Enable 0 = Normal (no power save), 1 = Global Counter power save enable
			RAMPHIGH	3	0	Internal Ramp DAC set All High 0 = Normal operation, 1 = DAC set All High
			FLYBTIME	2	0	Ramp Fly back Time 0 = 800 nSec, 1 = 500 nSec
			RAMPDLY	1-0	1	Ramp Delay by DCLK 00 = -1/2 DCLK, 01 = No Delay, 10 = +1/2 DCLK
07	RAMPCM	R/W	RAMPMON	4	0	Internal Ramp Amp Monitor Enable
			DACMON	3	0	Internal Ramp DAC Monitor Enable
			RAMPCM	2-0	4	Ramp Amp Current Control (000 = -100%(Power down), 001 = -75%, 010 = -50%, 011 = -25%, 100 = ±0%, 101 = +25%, 110 = +50%, 111 = +75%)
08	VDACMX	R/W		7-0	0	Ramp DAC Max Value Control, -40% ~ +40 %
09	BIASN	R/W	EXT_VREF	2	0	External VREF Enable
			BIASN	1-0	1	00 = bias current off 01 = bias current set to 0.5nA 10 = bias current set to 1nA
0A	GAMMASET	R/W	PMPHOLD_EN	4	0	VCOM PUMP hold enable when VGN sampling time 0 = Normal pumping, 1 = Pump hold function enable
			VGN SH_EN	3	0	VGN Sample & Hold Enable 0 = VGN SH Bypass, 1 = Enable VGN SH output
			IDSTEP	2-0	0	Current level for gamma sensor
0B	VCOMMODE	R/W	ISEN_EN	3-2	0	VCOM I-Sensor Enable
			VCOMAUTO	1-0	0	00 = AUTO1 mode 01 = AUTO2 mode 10 = MANUAL mode
0C	VCOMCTL	R/W	SS_BYPASS	7	0	VCOM Soft Start Bypass mode 0 = Soft Start function enable, 1 = Soft Start Bypass
			VCKDUTY	6-4	3	VCOM Clock Duty Control (High:Low) 0=1:7, 1=1:3, 2=3:5, 3=1:1, 4=5:3, 5=3:1, 6=7:1, 7=Don't use
			VCKSEL	3-2	3	VCOM Clock Select 0=125KHz, 1=250KHz, 2=500KHz, 3=800KHz
			VCOMSS	1-0	1	VCOM Soft Start Delay Time Mode 0 = 2mS, 1 = 4mS, 2 = 8mS, 3 = 16mS
0D	VGMAX	R/W		7-0	0D	Fine adjustment for VGMAX level (default = 4.95V)
0E	VCOM	R/W		7-0	51	VCOM manual setting (used when VCOMMODE = 01 or 10 , default = -2.3V)
0F	IDRF	R/W	IDRF_COARSE	7-5	1	Coarse adjustment for array reference current
			IDRF_FINE	4-0	10	Fine adjustment for array reference current
10	DIMCTL	R/W		6-0	64	Dimming level control (default = 1X IDRF)

11	TREFDIV	RW		5-0	1E	Temp. Sensor Reference Clock Divider
12	TEMPOFF	RW		7-0	88	Temp. Sensor Offset
13	TUPDATE	RW		7-0	FF	Number of frames per TEMPOUT update (Data range 02H ~ FFH) Update Time = (TUPDATE+1) * PERIOD _{FRAME} PERIOD _{FRAME} = 16.6 mSec when using 60Hz Video
14	TEMPOUT	RO		7-0	-	Temperature Sensor Readout
15	ANGPWRDN	RW	IENPD	7	0	ISEN Power Down
			IDMAXPD	6	0	IDMAX Power Down
			VCOMP	5	0	VCOM Power Down
			VREFPD	4	0	VREF Power Down
			GMPENPD	3	0	Gamma Sensor Power Down
			VCPENPD	2	0	VCOM Sensor Power Down
			TSENP	1	0	Temperature Sensor Power Down
TREFPD	0	0	Temperature Reference Power Down			
16	SYSPWRDN	RW	PDWN	4	0	All System Power Down (Override all analog power down, except POR50VPD, POR25VPD)
			RAMP	3	0	RAMP DAC AMP Power Down
			DACP	2	0	RAMP DAC Power Down
			POR50VPD	1	0	5V POR Power Down
			POR25VPD	0	0	2.5V POR Power Down
17	TPMODE	RW		2-0	0	Select test pattern for Built-In-Test-Mode (BURNIN pin = 'High') 000= Burn-in (all white), 001=Color Bar, 010=16 level gray scale 011=Checker Board, 100=Vertical Line, 101= Horizontal Line, 110=Grid Pattern
18	TPLINWTH	RW		7-0	0	Line Test Pattern Line Width (0=1pixel, 1=2pixel, ..., 255=256pixel)
19	TPCOLSP	RW		7-0	0	Line Test Pattern Column Space (0=1pixel, 1=2pixel, ..., 255=256pixel)
1A	TPROWSP	RW		7-0	0	Line Test Pattern Row Spce (0=1pixel, 1=2pixel, ..., 255=256pixel)
1B	TPCOLOR	RW	TPBGCLR	6-4	0	Line Test Pattern Background Color (RGB)
			TPFGCLR	2-0	7	Line Test Pattern Forground Color (RGB)
1C	DIGTEST	RW		7	0	FB_FAST
				6	0	FB_SLOW
				5	0	SETB_EN
				4	0	CPREQ_IN
				3	0	TEST_EN
				2	0	CTST_RESET
				1-0	0	TESTMODE
2E	PUCTRL	RW	PUCEN	3	0	Auto Power-Up sequence override Enable
			VIDEN	2	0	Video Display Enable
			VCMEN	1	0	VCOM Enable
			VANEN	0	0	VAN Enable
2F	HIDDEN	RW		2	0	VCOM_OSC enable
				1	0	STB_EN_IN polarity invert
				0	0	ROW_ODDSEL_IN polarity invert

11. DETAILED REGISTER DESCRIPTIONS

11.1 STAT (00h)

Name	STAT
Address	00h
Mode	Read Only

Bit Name	Bit#	Reset Value	Description
CID	3	-	Indicates monochrome or color display
REV	2-0	0	Silicon revision number; Rev. 1 = 0

Bits REV in this register indicate the revision number of the silicon backplane design, with 0 corresponding to the first silicon known as Rev. 1.

Bit CID indicates the version of silicon backplane with “0” for a monochrome display and “1” for the color version.

11.2 VINMODE (01h)

Name	VINMODE
Address	01h
Mode	Read / Write

Bit Name	Bit#	Reset Value	Description
WRDISABLE	4	0	I ² C register write disable
SET_ENABLE	3	0	ENABLE active level
SET_FIELD	2	0	Field polarity
VSYNCPOL	1	0	VSYNC polarity
HSYNCPOL	0	0	HSYNC polarity

WRDISABLE:

- 1 = write protected (all other registers become read only)
- 0 = write enable (all registers can be updated externally via I²C) (default)

SET_ENABLE:

- 0 = the active state of the ENABLE input is set “low” (default)
- 1 = the active state of the ENABLE input is set “high”

The ENABLE input pin is used to implement 3D video modes using a single RGB source, with two consecutive frames carrying information for each eye. The microdisplay can be programmed for either an active high or low ENABLE input using the SET_ENABLE bit, allowing a single video signal to be used with two displays. In such a configuration, one display scans and displays, while the other one holds and displays. The active state of the ENABLE input corresponds to the video data being scanned and displayed by the microdisplay.

To implement the Frame Sequential 3D Mode according to the VESA Standard for Stereoscopic Display Hardware, the display for the left eye is programmed with SET_ENABLE=1 and the right eye display is programmed with SET_ENABLE=0. Consequently, the data for the left eye is supplied and displayed when ENABLE=1 while the display for the right eye displays the previous frame of data.

The ENABLE input pin is also used to indicate field polarity in non-3D interlaced modes. In this mode the SET_FIELD bit determines the field polarity when ENABLE is active.

SET_FIELD:

- 0 = Odd Field when ENABLE=Active (default)
- 1 = Even Field when ENABLE=Active

The SET_FIELD register determines the field polarity of the video signal when the ENABLE pin is active.

VSYNCPOL:

- 0 = Negative Sync (default)
- 1 = Positive Sync

HSYNCPOL:

- 0 = Negative Sync (default)
- 1 = Positive Sync

The SYNCPOL registers are used to determine whether the positive or negative edge of the external synchronization clocks (HSYNC and VSYNC) is used as the active transition by the internal display sequencers and control logic.

11.3 DISPMODE (02h)

Name	DISPMODE
Address	02h
Mode	Read / Write

Bit Name	Bit#	Reset Value	Description
DISPOFF	5	1	Display On/Off control
3D-MODE	4	0	3D Mode control
SCMODE	3-2	0	Progressive or Interlaced scan mode selection
VSCAN	1	0	Vertical Scan direction
HSCAN	0	0	Horizontal Scan direction

DISPOFF:

- 0 = Display is turned ON

1 = Display is turned OFF (default)

The display starts in the OFF state by default and requires a command via the serial port to be turned on.

3D-MODE:

0 = Normal display mode (default)

1 = Time Sequential 3D mode

These bits are used to set the 3D mode of operation in conjunction with SET_ENABLE (bit #3 of the VINMODE register) and the Enable input. In Frame Sequential Mode each video frame contains information for either the left or right eye. When 3D-MODE="1" the SCMODE bit in the DISPMODE register is overridden to Progressive Scan Mode (0h). The following description for Frame Sequential operation assumes the source is in compliance with the VESA standard, where the data for the left eye is provided while the Enable signal is at the logic high level, and the data for the right eye display is provided while the Enable signal is at the logic low level. The Enable input signal is sampled into the circuit by a flip-flop clocked on the falling edge of VSYNC and the sampled value is used for the next frame. (The Enable signal is generated by the graphics software and may not be synchronized to the VSYNC signal).

To activate the stereovision mode, the right eye display needs to be configured with Enable active low (SET_ENABLE="0", bit #3 of the VINMODE register). This will allow the right eye microdisplay to hold the previous frame while the Enable input is high. The left eye display needs to be configured with Enable active high (SET_ENABLE="1", bit #3 of the VINMODE register). Thus the two Enable inputs can be tied together to the incoming Stereo Sync signal provided by the graphics adapter (or other custom source).

SCMODE:

00 = Progressive scan mode (default)

01 = Interlaced scan mode

1X = Pseudo-interlaced mode

Interlaced modes are limited to a maximum of 512 and a minimum of 240 active rows per field.

VSCAN:

0 = Top to Bottom vertical scan direction (default)

1 = Bottom to Top vertical scan direction

HSCAN:

0 = Left to Right horizontal scan direction (default)

1 = Right to Left horizontal scan direction

11.4 TOPPOS (03h)

Name	TOPPOS
-------------	--------

Address	03h
Mode	Read / Write

Bit Name	Bit#	Reset Value	Description
	5-0	14	Top position of first active row

This register, along with register BOTPOS, is used to set the vertical position of the active display window within the 520 available rows of pixels. In VGA mode the active window can be moved by +/-20 pixels from the center (default) position. When TOPPOS is increased, register BOTPOS must be decreased by the same value so that the sum of the two remains equal.

11.5 BOTPOS (04h)

Name	BOTPOS
Address	04h
Mode	Read / Write

Bit Name	Bit#	Reset Value	Description
	5-0	14	Bottom position of last active row

This register, along with register TOPPOS, is used to set the vertical position of the active display window within the 520 available rows of pixels. In VGA mode the active window can be moved by +/-20 pixels from the center (default) position. When TOPPOS is increased, register BOTPOS must be decreased by the same value so that the sum of the two remains equal.

11.6 ROWRESET (05h)

Name	ROWRESET
Address	05h
Mode	Read / Write

Bit Name	Bit#	Reset Value	Description
	7-0	0	Row duty rate control

This register is used to set the number of line cycles (in steps of 2) during which each row is active in any frame period. Each row is driven to black during the non-active line cycles.

ROWRESET (dec)	Active Line Cycles	Active Duty Rate (%)	Note
0	all	100	Pixels active for entire frame period
1	2	$2 * T_{HSYNC} / T_{FRAME}$	509 total HS cycles / frame
n	2*n	$2 * n * T_{HSYNC} / T_{FRAME}$	
>254	all	100	Pixels active for entire frame period

11.7 RAMPCTL (06h)

Name	RAMPCTL
Address	06h
Mode	Read / Write

Bit Name	Bit#	Reset Value	Description
GCPSAVE	4	0	Global counter power save enable
RAMPHIGH	3	0	Set internal RAMP DAC high
FLYBTIME	2	0	RAMP Flyback time
RAMPDLY	1-0	1	RAMP delay in DCLK cycles

GCPSAVE:

- 0 = Power save mode disable (default)
- 1 = Power save mode enable

The GCPS register is used to enable the Global Counter power saving option in which the internal D/A converter operates in a hybrid 8-bit/10-bit conversion mode.

RAMPHIGH:

- 0 = Normal operation (default)
- 1 = DAC set to all high output

The RAMPHIGH register is used to set internal RAMPDAC to all high output mode for test purposes.

FLYBTIME:

- 0 = 500 ns (default)
- 1 = 800 ns

The FLYBTIME register is used to set the fly-back time for the internal RAMP.

RAMPDLY:

- 00 = - ½ DLCK
- 01 = no delay (default)
- 10 = + ½ DCLK

The RAMPDLY2 register is used to adjust the starting position of the internal RAMP.

11.8 RAMPCM (07h)

Name	RAMPCM
Address	07h

Mode	Read / Write
-------------	--------------

Bit Name	Bit#	Reset Value	Description
RAMPMON	4	0	Internal RAMP Amp monitor enable
DACMON	3	0	Internal RAMP DAC monitor enable
RAMPCM	2-0	4	RAMP Amp current control

RAMPMON:

- 0 = Disable internal RAMP Amp monitoring (default)
- 1 = Enable internal RAMP Amp monitoring

The RAMPMON register is used to enable monitoring of the internal RAMP amplifier output signal.

DACMON:

- 0 = Disable internal RAMP DAC monitoring (default)
- 1 = Enable internal RAMP DAC monitoring

The DACMON register is used to enable testing of the internal RAMP DAC output signal.

RAMPCM:

- 000 = -100% (power down)
- 001 = -75%
- 010 = -50%
- 011 = -25%
- 100 = nominal (default)
- 101 = +25%
- 110 = +50%
- 111 = +75%

The RAMPCM register is used to set the operating bias current for the internal RAMP amplifier. The settings reduce or increase the current by a percentage of the nominal (default) value.

11.9 VDACMX (08h)

Name	VDACMX
Address	08h
Mode	Read / Write

Bit Name	Bit#	Reset Value	Description
	7-0	0	RAMP DAC maximum value control

Register VDACMX is used to adjust the maximum value of the internal RAMP DAC signal by -40% to +40% of the nominal value.

NOTE: The normal operating value for VDACMX should be set to 78h.

The typical dependence of display luminance on VDACMX(dec) is shown in Figure 19. The luminance is seen to saturate for VDACMX greater than 79h in this sample. For normal operation VDACMX should be set to about 90 to 95% of the saturation value as shown in the figure.

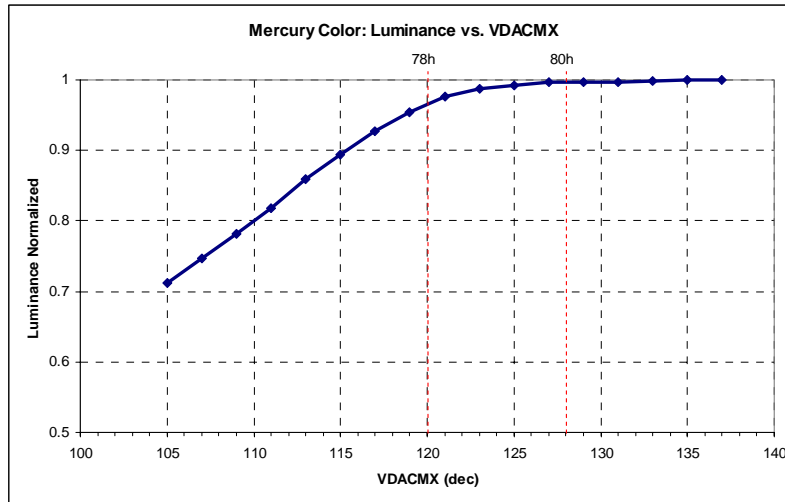

Figure 19: Luminance dependency on VDACMX

11.10 BIASN (09h)

Name	BIASN
Address	09h
Mode	Read / Write

Bit Name	Bit#	Reset Value	Description
EXT_VREF	2	0	Enable external VREF
BIASN	1-0	1	Set pixel bias current

EXT_VREF:

- 1 = enable the external VREF source
- 0 = use the internal VREF source (default)

Note: This option not available on the current package – use the default setting only.

BIASN:

- 00 = pixel bias current is turned off
- 01 = pixel bias current set to 0.5nA (default)
- 10 = pixel bias current set to 1nA

The BIASN register is used to set the sink current applied in each pixel cell. It is recommended to use the BIASN=01 setting in normal operation.

11.11 GAMMASET (0Ah)

Name	GAMMASET
Address	0Ah
Mode	Read / Write

Bit Name	Bit#	Reset Value	Description
PMPHOLD_EN	4	0	VCOM pump hold enable
VGNSH_EN	3	0	VGN sample & hold enable
IDSTEP	2-0	0	Current level for gamma sensor

PMPHOLD_EN:

- 0 = Normal operation, pump hold disabled (default)
- 1 = Enable pump hold during VGN sampling time

The PMPHOLD_EN register is used to disable the VCOM converter switch during the VGN sampling time to reduce noise pickup.

VGNSH_EN:

- 0 = Bypass the VGN sample & hold function (default)
- 1 = Enable the VGN sample & hold function

The VGNSH_EN register is used to activate the internal sample & hold function provided at the VGN output pin.

IDSTEP:

- 0h \approx IDRFB/128
- 1h \approx IDRFB/64
- 2h \approx IDRFB/32
- 3h \approx IDRFB/16
- 4h \approx IDRFB/8
- 5h \approx IDRFB/4
- 6h \approx IDRFB/2
- 7h = IDRFB

The IDSTEP register is used to set the current level for the gamma sensor. The corresponding output voltage is provided at pin VGN.

A minimum of 10msec following an IDSTEP register update should be allowed for the VGN signal to settle before sampling. In addition, sampling of the VGN signal should be carried out during the Frame Blanking time.

11.12 VCOMMODE (0Bh)

Name	VCOMMODE
Address	0Bh
Mode	Read / Write

Bit Name	Bit#	Reset Value	Description
ISEN_EN	3-2	0	Enable the VCOM current sensor
VCOMAUTO	1-0	0	Set internal VCOM supply mode

ISEN_EN:

TBD

VCOMAUTO:

This register sets the operating mode of the internal VCOM dc-dc converter.

- 00 = AUTO1 mode (default)
- 01 = AUTO2 mode
- 10 = MANUAL mode

In the AUTO1 mode, the VCOM converter uses an internal current reference to maintain a fixed OLED current level, which is defined by registers DIMCTL and IDRF.

In the AUTO2 mode, the VCOM converter regulates the OLED current level when the VCOM supply is below a set threshold (defined by the VCOM register), and clamps the output to the threshold level when conditions call for a VCOM output above the threshold level.

In the Auto 3 mode, the VCOM converter uses a voltage reference signal to maintain a fixed cathode supply voltage. The value of the cathode voltage is set by register VCOM.

11.13 VCOMCTL (0Ch)

Name	VCOMCTL
Address	0Ch
Mode	Read / Write

Bit Name	Bit#	Reset Value	Description
SS_BYPASS	7	0	Bypass the VCOM soft start mode
VCKDUTY	6-4	3	VCOM clock duty control
VCKSEL	3-2	3	VCOM clock select
VCOMSS	1-0	1	VCOM soft start delay time

SS_BYPASS:

- 0 = Normal operation, soft-start function enabled (default)
- 1 = Disable the VCOM soft-start function

VCKDUTY:

- 0h = 1:7
- 1h = 1:3
- 2h = 3:5
- 3h = 1:1 (default)
- 4h = 5:3
- 5h = 3:1
- 6h = 7:1
- 7h = don't use

Register VCKDUTY sets the VCOM clock duty ratio (high:low).

VCKSEL:

- 0h = 125 kHz
- 1h = 250 kHz
- 2h = 500 kHz
- 3h = 800 kHz (default)

Register VCKSEL sets the operating frequency of the VCOM clock.

VCOMSS:

- 0h = 2 ms
- 1h = 4 ms (default)
- 2h = 8 ms
- 3h = 16 ms

Register VCMOSS sets the soft-start duration during startup of the VCOM converter.

11.14 VGMAX (0Dh)

Name	VGMAX
Address	0Dh
Mode	Read / Write

Bit Name	Bit#	Reset Value	Description
	7-0	0D	Fine adjustment for VGMAX level

- 00h = 5 (VAN = 5V)
- 0Dh = 4.95 (default)
- FFh = 4

$$\text{VGMAX level} = \text{VAN} * (1 - 0.2 * \text{VGMAX}(\text{dec}) / 255)$$

This register sets the pixel voltage at which the maximum OLED current is regulated. It should be slightly below the VAN supply to prevent saturation of the video buffer amplifiers.

11.15 VCOM (0Eh)

Name	VCOM
Address	0Eh
Mode	Read / Write

Bit Name	Bit#	Reset Value	Description
	7-0	51	VCOM manual setting

Cathode supply as a function of VCOM setting:

VCOM(h)	FF	F0	E0	D0	C0	B0	A0	90	80	70	60	51*	40	30
Voltage	-0.29	-0.38	-0.47	-0.59	-0.72	-0.85	-1.0	-1.2	-1.43	-1.7	-2.0	-2.4	-2.97	-3.68

*default value

Register VCOM[7,0] sets the fixed output level for the internal VCOM inverter when VCOMMODE =01 or 10. There is no compensation for the variation in OLED behavior with temperature in this mode of operation. As a result, a setting at room temperature will not necessarily result in optimal contrast and the same luminance at other temperatures. The default setting (51h) will result in a cathode supply $\approx -2.3V$. The typical dependency of luminance on the VCOM setting in manual mode is given in Figure for a color display.

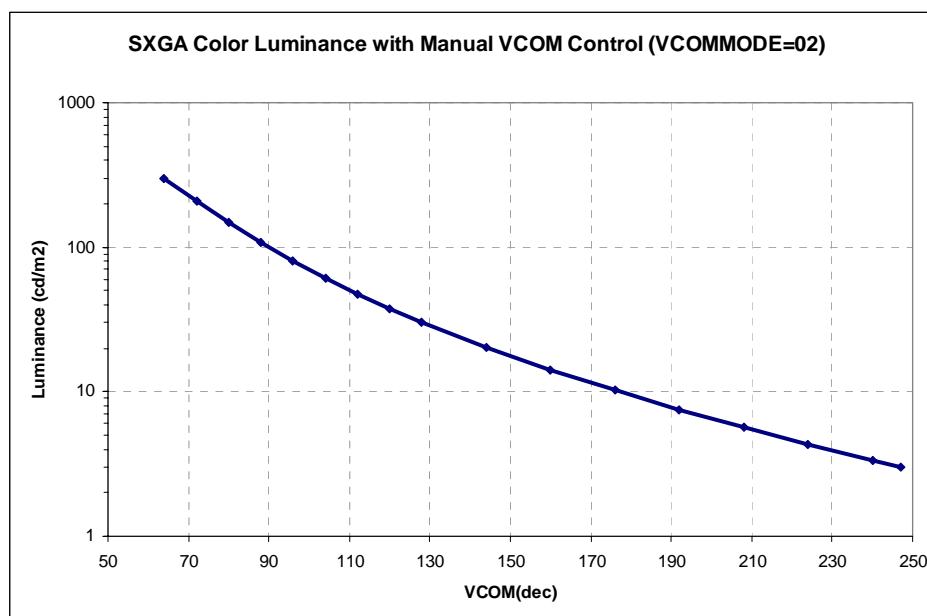

Figure 18: Typical luminance dependency on manual VCOM setting

11.16 IDRF (0Fh)

Name	IDRF
Address	0Fh
Mode	Read / Write

Bit Name	Bit#	Reset Value	Description
IDRF_COARSE	7-5	1	Coarse adjustment for array reference current
IDRF_FINE	4-0	10	Fine adjustment for array reference current

IDRF_COARSE:

IC#
 0h = 0
 1h = 0.5 (default)
 2h = 1.5
 3h = 2.5
 4h = 3.5

IDRF_FINE:

IF#
 00h = 0
 01h = 1/32
 ...
 10h = 16/32 (default)
 ...
 1Fh = 31/32

Register IDRF is used to set the maximum OLED current, which determines the luminance level for the display. The luminance will be directly proportional to the IDRF factor (sum of IC# and IF#) and the reference luminance LDEF given by the following expression:

$$LMAX = LDEF * (IC# + IF#) \quad \text{in cd/m}^2$$

where the luminance for a color display is $LDEF \approx 150 \text{cd/m}^2$ at the default settings (see table below).

IDRF (hex)	LMAX / LDEF
0	0
10	0.5
20	0.5
30	1 (default)
40	1.5
50	2
60	2.5
70	3
80	3.5

11.17 DIMCTL (10h)

Name	DIMCTL
Address	10h
Mode	Read / Write

Bit Name	Bit#	Reset Value	Description
	6-0	64	Dimming level control

00h = 0
 01h = 1% of LMAX
 ...
 64h = 100% of LMAX
 ...
 7Fh = 127% of LMAX

This register provides linear control of the display luminance level ranging from 0 to 127% in steps of 1%. The default value of 64h is equal to 100% of the luminance defined by register IDRF.

This register is only operational in Auto VCOM mode (VCOMMODE=00).

11.18 TREFDIV (11h)

Name	TREFDIV
Address	11h
Mode	Read / Write

Bit Name	Bit#	Reset Value	Description
	5-0	1E	Temperature sensor reference clock divider adjust

The register TREFDIV is used to adjust the slope of the temperature readout sensor, TEMPOUT, to correspond to the desired operating range of the display. The default setting is intended to support a full scale temperature range of -40 to 80°C, although the setting is best determined by a calibration measurement of the display in its final assembly.

See the description for register TEMPOUT.

11.19 TEMPOFF (12h)

Name	TEMPOFF
Address	12h
Mode	Read / Write

Bit Name	Bit#	Reset	Description
----------	------	-------	-------------

		Value	
	7-0	88	Temperature sensor offset adjust

The register TEMPOFF is used to adjust the offset of the temperature readout sensor, TEMPOUT, to correspond to the desired operating range of the display. The default setting is intended to support a full scale temperature range of -40 to 80°C, although the setting is best determined by a calibration measurement of the display in its final assembly.

See the description for register TEMPOUT.

11.20 TUPDATE (13h)

Name	TUPDATE
Address	13h
Mode	Read / Write

Bit Name	Bit#	Reset Value	Description
	7-0	FF	Number of frames per TEMPOUT update

This register sets the update rate of the Temperature Sensor reading, TEMPOUT. The time between sensor updates is given by:

$$\text{Update Time} = (\text{TUPDATE}(\text{decimal}) + 1) * T_{\text{FRAME}}$$

where the frame period T_{FRAME} is equal to 16.6 ms for 60Hz video. The valid range for TUPDATE is 02h to FFh.

11.21 TEMPOUT (14h)

Name	TEMPOUT
Address	14h
Mode	Read Only

Bit Name	Bit#	Reset Value	Description
	7-0	-	Temperature sensor readout

Register TEMPOUT provides an 8bit digital output that is linearly proportional to the chip temperature. The VGA display temperature sensor is designed around a P-N junction. The output of the junction is sampled by an internal current to voltage converter, digitized and stored into a dedicated 8-bit register TEMPOUT. The sampling rate is controlled by configuration register TUPDATE (13H). By default the temperature sensor is updated once every 255 frames. Two registers are used to set the sensor gain (TREFDIV) and sensor offset (TEMPOFF). The temperature sensor can be powered down when not used by setting TSENPD =1 in the PWRDN register.

The temperature sensor is intended to provide a full-scale reading over a temperature range defined by the user. Assuming that the desired operating temperature range is defined by T_{MIN} and T_{MAX} , the expected sensor response would be as follows:

$$TEMPOUT(dec) = A * temp + B$$

where temp is the chip temperature in degrees Celsius, and A and B are given by:

$$A = \frac{255}{T_{MAX} - T_{MIN}}$$

$$B = \frac{-255 * T_{MIN}}{T_{MAX} - T_{MIN}}$$

The actual sensor response is determined by registers TREFDIV and TEMPOFF through the following relationship:

$$TEMPOUT(d) = k_1 * TREFDIV(d) * temp + k_2 + TEMPOFF(d)$$

The constants k_1 and k_2 are dependent on properties of the silicon and package assembly. For example, the average register settings needed to achieve a working temperature range of -60°C to +80°C are given by the following values for package A04-500463-01:

$$TREFDIV(d) = 25$$

$$TEMPOFF(d) = 93$$

Using these values will result in a variation in temperature reading from part to part due to manufacturing tolerances. To get a reasonably good sensor performance it is usually enough to just find the optimum value for TEMPOFF which requires only one measurement at room temperature. Increased accuracy can be obtained for a specific part by performing the calibration measurements described below.

To find the optimum value for TREFDIV do the following:

- Place the display in a temperature controlled environment, e.g. an oven
- Set TREFDIV=25d=19h and TEMPOFF=0
- Set DISPMODE=20h (turn off the display)
- Read TEMPOFF at several ambient temperatures, e.g. 0°C, 20°C, 40°C, 60°C
- Take the slope to find the sensor response, $A_{MEAS} = dTEMPOUT(d)/dtemp$
- The optimum value for TREFDIV is then given by

$$TREFDIV_{OPT} = 25 * \frac{1.82}{A_{MEAS}}$$

To find the optimum value for TEMPOFF do the following:

- Set TREFDIV=25d=19h (or the optimum value) and TEMPOFF=0
- Set DISPMODE=20h (turn off the display)

- Allow several minutes to stabilize and then read $TEMPOUT_{AMB}$ and the ambient temperature T_{AMB}
- The optimum value for $TEMPOFF$ is then given by

$$TEMPOFF_{OPT} = 1.82 * T_{AMB} + 109 - TEMP_{OUT}_{AMB}$$

With these settings, the microdisplay temperature can be found from the sensor reading through the following relationship:

$$T(^{\circ}C) = \frac{140}{255} * TEMP_{OUT}(d) - 60$$

Temperatures below $-60^{\circ}C$ will return a $TEMP_{OUT}$ reading of 0 and temperatures above $+80^{\circ}C$ will return a hexadecimal value of FF.

11.22 ANGPWRDN (15h)

Name	ANGPWRDN
Address	15h
Mode	Read / Write

Bit Name	Bit#	Reset Value	Description
IENPD	7	0	IEN power down
IDMAXPD	6	0	IDMAX power down
VCOMP	5	0	VCOM power down
VREFPD	4	0	VREF power down
GMPENPD	3	0	Gamma sensor power down
VCSNP	2	0	VCOM sensor power down
TSENDP	1	0	Temperature sensor power down
TREFPD	0	0	Temperature reference power down

IENPD:

- 1 = VCOM current limit sensor is powered down
- 0 = normal operation (default)

IDMAXPD:

- 1 = IDMAX function is powered down
- 0 = normal operation (default)

VCOMP:

- 1 = VCOM generator is powered down
- 0 = normal operation (default)

VREFPD:

1 = the VREF reference source is powered down
0 = normal operation (default)

GMSENPD:

1 = the Gamma sensor is powered down
0 = normal operation (default)

VCSNEPD:

1 = the VCOM sensor is powered down
0 = normal operation (default)

TSENDP:

1 = the Temperature Sensor is powered down
0 = the Temperature Sensor is operating normally (default)

TREFPD:

1 = the Temperature reference is powered down
0 = normal operation (default)

11.23 SYSPWRDN (16h)

Name	SYSPWRDN
Address	16h
Mode	Read / Write

Bit Name	Bit#	Reset Value	Description
PDWN	4	0	All systems power down
RAMPPD	3	0	RAMP DAC amp power down
DACPD	2	0	RAMP DAC power down
POR50VPD	1	0	5V power-on-reset power down
POR25VPD	0	0	2.5V power-on-reset power down

PDWN:

1 = all systems are powered down
0 = normal operation (default)

By setting the PDWN bit to a “1” the chip enters a deep sleep mode in which all functions including the I²C interface are powered down in order to minimize power consumption. The data, sync and clock inputs should be inactive and held low to achieve the lowest power consumption. An on-chip Address Detection circuit monitors the I²C input lines and resets the PDWN bit when it detects the correct I²C address, restoring the display to operating mode.

All register settings are saved in the power down mode and the display will restart in its previous state when normal operation is resumed.

RAMPPD:

- 1 = internal RAMP DAC amplifier is powered down
- 0 = normal operation (default)

DACPD:

- 1 = internal RAMP DAC is powered down (use when external RAMP option is enabled)
- 0 = internal RAMP DAC is operational (default)

The internal RAMP DAC generator may be power down if an external RAMP source is used.

POR50VPD:

- 1 = the 5V power-on-reset circuit is powered down
- 0 = normal operation (default)

POR25VPD:

- 1 = the 2.5V power-on-reset circuit is powered down
- 0 = normal operation (default)

11.24 TPMODE (17h)

Name	TPMODE
Address	17h
Mode	Read / Write

Bit Name	Bit#	Reset Value	Description
	2-0	0	Select test pattern for Burn-In mode

The BI pin must be tied high to activate the Burn-In test mode which can be used to check display functionality without the presence of external video data or clock signals. In this mode the display generates data, syncs and the pixel clock internally for several different video patterns. The TPMODE register is used to select one of the built-in test patterns in Burn-In mode via the serial interface.

- 000 = all white pattern (default)
- 001 = color bars
- 010 = gray scale (without gamma correction)
- 011 = checkerboard pattern
- 100 = alternating columns pattern
- 101 = alternating rows pattern
- 110 = grid pattern
- 101 = all black

Use with registers TPLINWTH, TPCOLSP, TPROWSP and TPCOLOR to modify the patterns according to the following table.

Test Pattern Name	TPMODE (17H)	TPLINWTH (18H)	TPCOLSP (19H)	TPROWSP (1AH)	TPFGCLR (1BH:2-0)	TPBGCLR (1BH:6-4)
All White	000	X	X	X	X	X
Color Bar	001	X	X	X	X	X
Gray Scale	010	X	X	X	X	X
Checker Board	011	X	X	X	X	X
Alternating Column	100	LW	CS	X	111	000
Alternating Row	101	LW	X	RS	111	000
Grid Pattern	110	LW	CS	RS	111	000
All Black	101	X	X	X	000	000
All White	101	X	X	X	111	111
All Red	101	X	X	X	100	100
All Green	101	X	X	X	010	010
All Blue	101	X	X	X	001	001

X: Don't care, LW: Line Width (0~255), CS: Column Space (0~255), RS: Row Space (0~255)

11.25 TPLINWTH (18h)

Name	TPLINWTH
Address	18h
Mode	Read / Write

Bit Name	Bit#	Reset Value	Description
	7-0	0	Test pattern line width

This register is used to set the line width for the line-type test patterns.

- 0 = 1 pixel wide (default)
- 1 = 2 pixel wide
- ...
- 255 = 256 pixel wide

11.26 TPCOLSP (19h)

Name	TPCOLSP
Address	19h
Mode	Read / Write

Bit Name	Bit#	Reset Value	Description
	7-0	0	Test pattern column spacing

This register is used to set the column spacing for the column-type test patterns.

0 = 1 pixel space (default)
 1 = 2 pixel space
 ...
 255 = 256 pixel space

11.27 TPROWSP (1Ah)

Name	TPROWSP
Address	1Ah
Mode	Read / Write

Bit Name	Bit#	Reset Value	Description
	7-0	0	Test pattern row spacing

This register is used to set the row spacing for the row-type test patterns.

0 = 1 pixel space (default)
 1 = 2 pixel space
 ...
 255 = 256 pixel space

11.28 TPCOLOR (1Bh)

Name	TPCOLOR
Address	1Bh
Mode	Read / Write

Bit Name	Bit#	Reset Value	Description
TPBGCLR	6-4	0	Test pattern background color
TPFGCLR	2-0	7	Test pattern foreground color

This register is used to set the background and foreground colors (RGB) for certain test patterns.

11.29 DIGTEST (1Ch)

Name	DIGTEST
Address	1Ch
Mode	Read / Write

This register is used test purposes only and should not be modified by the user.

11.30 PUCTRL (2Eh)

Name	PUCTRL
Address	2Eh
Mode	Read / Write

Bit Name	Bit#	Reset Value	Description
PUCEN	3	0	Auto Power-up sequence override enable
VIDEN	2	0	Video display enable
VCMEN	1	0	VCOM enable
VANEN	0	0	VAN enable

These registers can be used to create a customized power-up sequence.

11.31 HIDDEN (2Fh)

Name	HIDDEN
Address	2Fh
Mode	Read / Write

This register is used for test purposes only and should not be modified by the user.

12. APPENDIX A: APPLICATION SYSTEM DIAGRAM

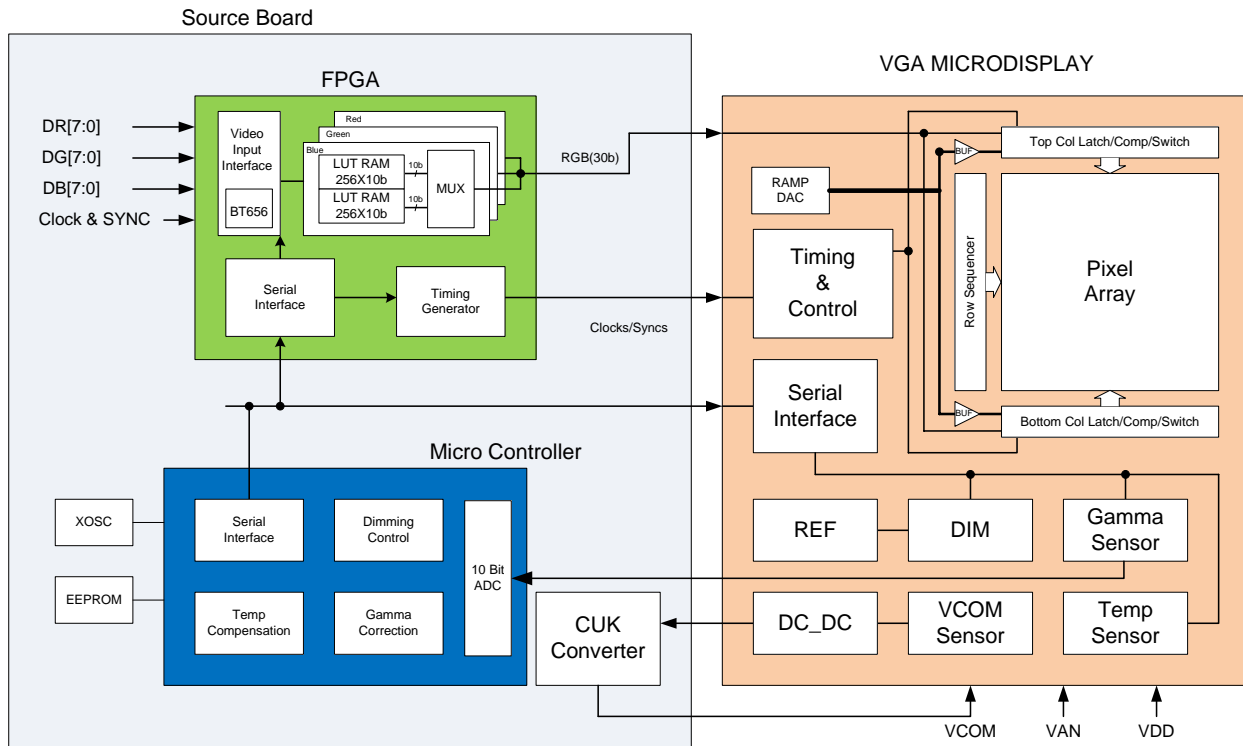

Figure 19: Block diagram of application reference system

13. APPENDIX B: MICRODISPLAY CARRIER BOARD

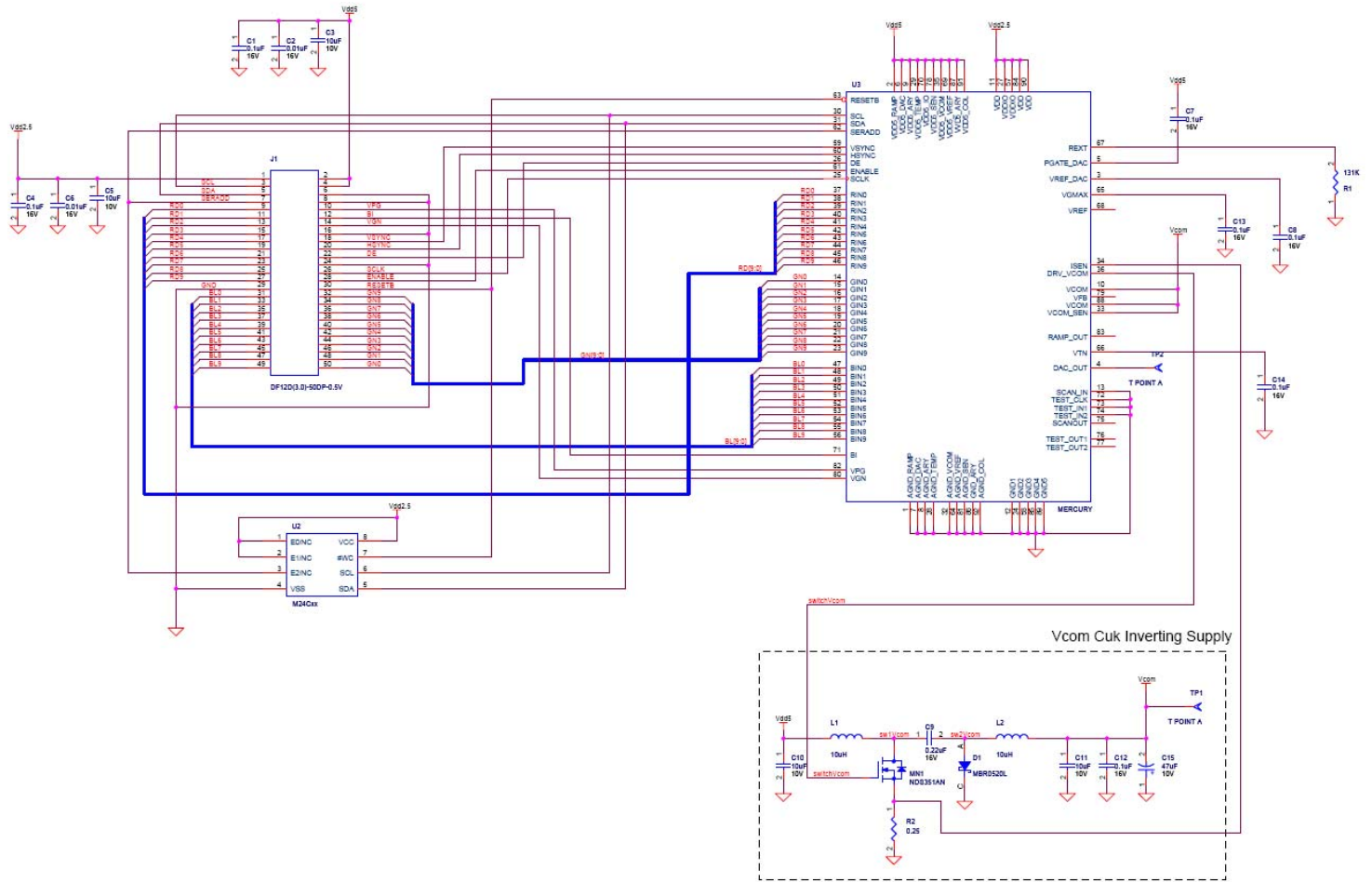
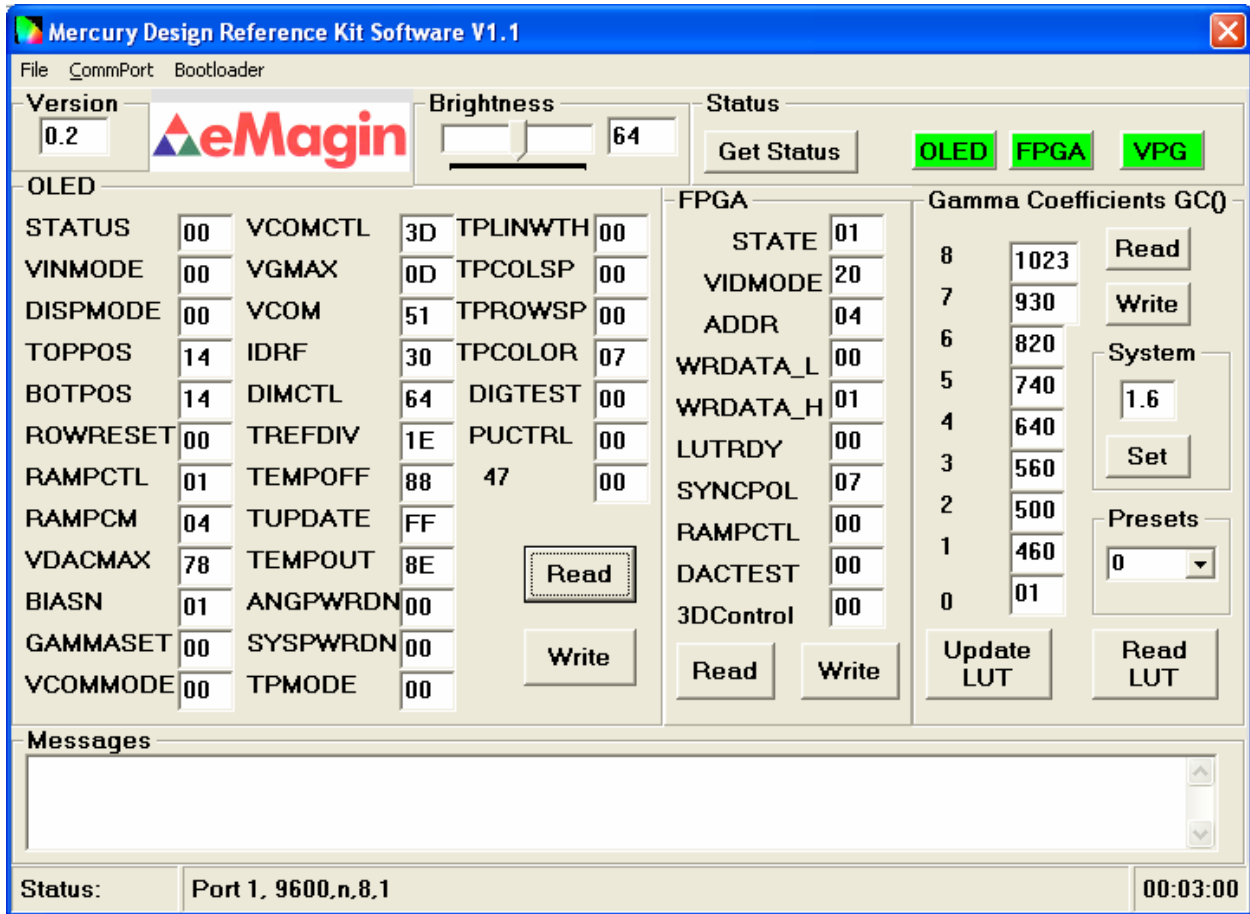

Figure 20: Color Carrier board schematic (D01-500588-01)

14. APPENDIX C: TYPICAL REGISTER SETTING



Recommended Register Settings for Normal Operation